

FIVE STAR REDEEMPTION

Haunted Hotel THREE PLAYER TECHNICAL MANUAL

January 3,2007



Features

- Bright Attention Grabbing Graphics & Cabinet
- Hot looking Lights
- Exciting Super Fast Skill Stop
- Oversized Highly Reliability Buttons
- Operator Programmable

Specifications

Parameter	Value	Units
Voltage	115	VAC
Frequency	60	HZ
Current	25	Amps
Weight	200	Pounds

Overview

Haunted Mansion consists of five lighted clock faces with motorized spinning swords, a player console with large buttons and numeric display for game play, speakers for sound effects, two coin dispensers, and a ticket dispenser. The objective is to skillfully stop the sword so that it points to a desirable position to maximize the number of points won.

TABLE OF CONTENTS

<i>Features</i>	1
<i>Specifications</i>	1
<i>Overview</i>	1
TABLE OF CONTENTS	2
<i>Game Play</i>	5
<i>Program Mode</i>	6
Viewing Stastical information	7
Statistical Information Calculations	8
Changing or Viewing Miscellaneous Settings.....	9
Resetting the Statistics.....	10
Diagnostics 71 – 75	11
Diagnostic 71- 75 Position Type & Pie Slice Definition.....	11
How To Run Diagnostics 71 – 75 Calibrating Spinners.....	12
Step’s 71 – 75 Diagnostic Layout.....	12
Troubleshooting Steps for Diagnostics 71 - 75.....	12
Running Diagnostics 76.....	13
Checking Spinner Motor, and Brake	13
Step 76 Diagnostic Layout	13
Troubleshooting Steps for Diagnostic 76	14
Running Diagnostics 77.....	14
Display Keypad Inputs	14
Running Diagnostics 78.....	14
Testing Ticket Dispenser	14
Troubleshooting Steps for Diagnostic 78	14
Running Diagnostics 79.....	15
Testing for Spinner Intermittent Problems	15
Step 79 Diagnostic Layout	15
Troubleshooting Steps for Diagnostic 79	15
Step 99 Viewing Software Identification.....	16
View and Changing Spinner Target Values	17
Viewing and Changing Spinner Target Values Steps 100 – 576.....	17
Steps 100 - 126	17
Viewing Spinner #1 Target Points.....	17
Steps 150 - 176	19
Changing Spinner #1 Target Types	19
Steps 200 - 226	20
Viewing Spinner #2 Target Points.....	20
Steps 250 - 276	21
Changing Spinner #2 Target Types	21
Steps 300 - 312	22
Changing Spinner #3 Target Points.....	22
Steps 350 - 362	23
Changing Spinner #1 Target Types	23

Steps 400 - 426	24
Viewing Spinner #4 Target Points	24
Steps 450 - 476	25
Changing Spinner #4 Target Types	25
Steps 500 - 526	26
Viewing Spinner #4 Target Points	26
Steps 550 - 576	27
Changing Spinner #5 Target Types	27
Wiring Diagrams.....	28
Top Level Interconnections.....	28
Figure 1 – Top Level Interconnect Diagram	28
Top Spinner Block Diagram Left Game	29
Top Spinner Block Diagram Center Game	30
Top Spinner Block Diagram Right Game	31
Top Spinner Wiring Left Game	32
Top Spinner Wiring Center Game	33
Top Spinner Wiring Pins 1-9 Center Game	34
Top Spinner Wiring Pins 10-15 Center Game	35
Top Spinner Wiring Right Game	36
Figure 3 - Control Panel	37
Figure 4 P16 & P22 Connections From The VTMUX Board To The Control Panel	38
Figure 5 P2 Connections From The VTMUX Board To The Control Panel	38
Figure 6 VTMux Board P32 to Smart Spinner Board #1,2,3,4 J4s W34	39
Figure 7 Power Supply to Spinner Boards #1-5 J1s7	40
Figure 8 Spinner #1 Subassembly	41
Figure 9 Spinner #2 Subassembly	42
Figure 10 Spinner #3 Subassembly	43
Figure 11 Spinner #4 Subassembly	44
Figure 12 Spinner #5 Subassembly	45
Figure 13 Spinner's 1 – 4 Neon Rings Wiring	46
Figure 14 VTMux Board P34 to Brake Solenoid	47
Figure 15 VTMUX board P34 To Spinner Motor	47
Figure 16 VTMux Board P32 to Spinner Shaft Encoder	48
Figure 17 VTMux Board J1 to Loudspeaker	49
Figure 18 VTMux Board P3 to Program Mode Button, Single Player,	49
Four Spinners Present, and Coin Acceptor	49
Figure 19 VTMux Board P42, P40, and P38 to Diode Boards P5s	50
Figure 20 VTMux Board P39 to Diode Board P7s	51
Figure 21A 60-pin Ribbon Cable TEE to Diode Board #2 P7	52
Figure 21B 60-pin Ribbon Cable TEE to Diode Board #3 P7	52
Figure 22 13.7 VDC Power Supply to 8051 VTMux Board P19	53
Figure 23 -13.7 VDC Power Supply to 8051 VTMux Board P43	53
Figure 20 Chassis Ground	53
Figure 21 - AUDIO Ground	53
Figure 24A VTMux Board P25 to Bonus Points Small Display J1	54
Figure 24B Bonus Points Small Display J2 to Bonus Spins Small Display J2	54
Figure 24C VTMux Board P26 to Credits/RPM/Total Points Large Display J4A	54
Figure 25A – VTMux Board J2 to Keypad KEY	55
Figure 25B - KEYPAD GUMB1 to Select Prize Small Display J2	55
Figure 26 - Protective Ground Wiring	56

Appendix A	57
Self diagnostic #1 Test Layout	57
Self Diagnostic #1	58
Self Diagnostic #1 ERROR CODE CHART	58
Appendix B	60
Troubleshooting Guide	60
Game will not power up	60
Pushbutton light does not illuminate	60
Game does not respond to pushing a flashing pushbutton.....	60
Does not respond when coin/token inserted	60
No sound.....	60
Does not dispense tickets.....	60
4-digit display always blank or shows gibberish.....	61
Spinner light-ring does not illuminate	61
Spinner does not spin.....	61
Spinner brake does not operate.....	61
SOME spinners CONSISTENTLY give wrong POINTS	61
SOME spinners INTERMITTENTLY give wrong POINTS	61
ALL spinners CONSISTENTLY give wrong POINTS.....	61
SOME spinners CONSISTENTLY cause a JUMP to wrong spinner.....	62
Appendix C	63
Technical Assistance	63
Five Star Redemption	64
Address and Telephone Numbers	64
8835 Shirley Avenue	64
Northridge, CA 91324	64
(818) 773-6057 Fax (818) 773-6064	64
Sales extension 232.....	64
Technical Support extension 235.....	64

Game Play

Haunted Mansion offers very fast and interesting play with many different strategies for maximizing the points you can win. There are *Multiple Spinners*, which allow the player to obtain a higher value of points as they go up from one spinner to the next.

- 1) Insert coin(s) to ready the game for play.
- 2) Push the *Start Button* to begin the *Spinner Spinning*.
- 3) There are several seconds in which to influence where the *Spinner* will stop by skillfully pushing the *Stop* and the *Slow Stop* button.
- 4) Points can be awarded and are displayed each time the *Spinner* is spun, however, you may choose to go to the next level and take the points.
- 5) Going to the next level increases the amount of points that can be awarded.

Program Mode

Program Mode allows the Game Operator the option of programming the Game by entering data through the Control Panel, which is located on the front panel of the cabinet. This mode includes viewing the game's statistical data, running diagnostics, and changing game play values.

To go into *Program Mode*, Hold Down both the "*" and "#" symbols together for 5 seconds on the Keypad or Press the *Program Mode* for 1 ½ seconds, and enter the number '11' on which will allow the operator to go into *Program Mode*.

Pressing the **FAST STOP BUTTON** will decrement the Value, Pressing the **START BUTTON** will increment the value. To increase the **STEP NUMBER** use the Numeric Keypad and press the "*", to decrease the **STEP NUMBER** press the "#" symbol. To Go to **STEPS** directly Hold down the "*" key while entering the **STEP NUMBER** in the keypad. Pressing the *Program Mode* or Holding Down both the "*" and "#" symbols will allow the operator to exit. The program button is located near the main board inside of the cabinet.

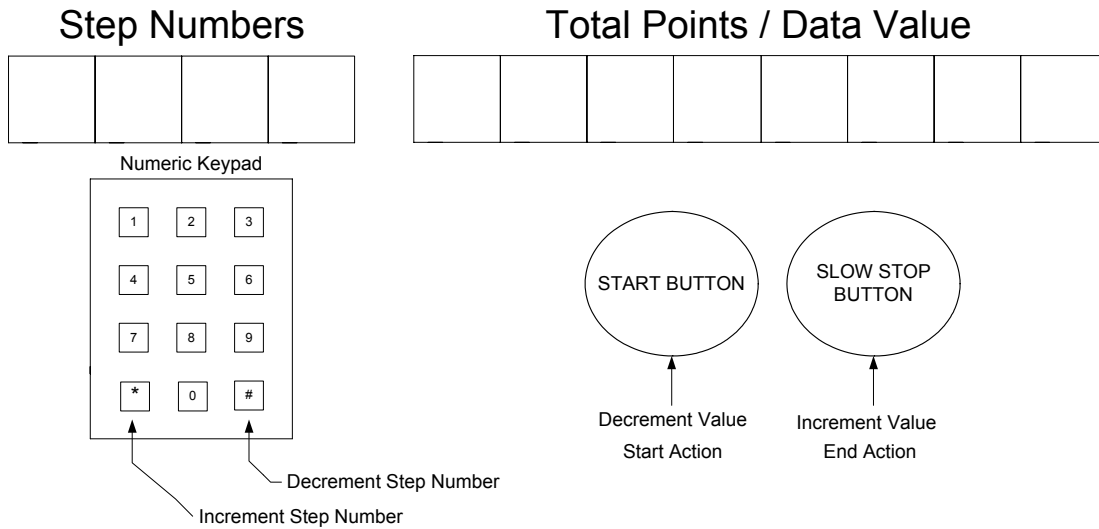

VIEWING STASTICAL INFORMATION

To increase the **STEP NUMBER** use the Numeric Keypad and press the ‘*’, to decrease the **STEP NUMBER** press the ‘#’ symbol. To Go to **STEPS** directly Hold down the “*” key while entering the **STEP NUMBER** in the keypad. To View Spinner’s 1 – 5 Data Press the **SLOW STOP BUTTON** to cycle through each spinner.

STEP #	DESCRIPTION
0	COINS TAKEN IN (SINCE RESET)
1	COINS TAKEN IN (LIFETIME)
2	TOTAL SPINS (SINCE RESET)
3	TOTAL SPINS (LIFETIME)
4	POINTS WON (SINCE RESET)
5	POINTS WON (LIFETIME)
6	CREDITS (SINCE RESET)
7	CREDITS (LIFETIME)
8	AVERAGE POINTS PER CREDIT (SINCE RESET)
9	AVERAGE POINTS PER CREDIT (LIFETIME)
10	AVERAGE SPINS PER CREDIT (SINCE RESET)
11	AVERAGE SPINS PER CREDIT LIFETIME)
12	TIMES SPINNER TAMPERED1-5 (SINCE RESET)
13	TIMES SPINNER TAMPERED1-5 (LIFETIME)
14	NUMBER OF TIMES SPINNER SPUN 1-5 (SINCE RESET)
15	NUMBER OF TIMES SPINNER SPUN 1-5 (LIFETIME)
16	NUMBER OF TIMES SPINNER JACKPOT1-5 (SINCE RESET)
17	NUMBER OF TIMES SPINNER JACKPOT1-5 (LIFETIME)
18	NUMBER OF TICKETS DISPENSED (SINCE LAST RESET)
19	NUMBER OF TICKETS DISPENSED (LIFETIME)
20	NUMBER OF TOTAL POINTS SPINNER # 1 – 5 (SINCE RESET)
21	NUMBER OF TOTAL POINTS SPINNER # 1 – 5 (LIFETIME)
22	AVERAGE NUMBER OF POINTS PER SPIN FOR SPINNER #1 – 5 (SINCE RESET)
23	AVERAGE NUMBER OF POINTS PER SPIN FOR SPINNER #1 – 5 (LIFETIME)
24	NUMBER OF TIMES SPINNER STOPPED ON POSITION WITH POINTS (SINCE RESET)
25	NUMBER OF TIMES SPINNER STOPPED ON POSITION WITH POINTS (LIFETIME)

STATISTICAL INFORMATION CALCULATIONS

$$\text{Step \# 8} \quad \begin{array}{l} \text{Average Points per Credit} \\ \text{Resettable} \end{array} = \frac{\text{Points Won (Step 4)}}{\text{Credits (Step 6)}}$$

$$\text{Step \# 9} \quad \begin{array}{l} \text{Average Points per Credit} \\ \text{Lifetime} \end{array} = \frac{\text{Points Won (Step 5)}}{\text{Credits (Step 7)}}$$

$$\text{Step \# 10} \quad \begin{array}{l} \text{Average Number Spins per 100 Credits} \\ \text{Resettable} \end{array} = \frac{\text{Total Spins (Step 2)} \times 100}{\text{Credits (Step 6)}}$$

$$\text{Step \# 11} \quad \begin{array}{l} \text{Average Number Spins per 100 Credits} \\ \text{Lifetime} \end{array} = \frac{\text{Total Spins (Step 3)} \times 100}{\text{Credits (Step 7)}}$$

Changing or Viewing Miscellaneous Settings

CHANGING OR VIEWING MISCELLANEOUS SETTINGS

Pressing the **SLOW STOP BUTTON** will increment the Value, Pressing the **START BUTTON** will decrement the value.

STEP #	DESCRIPTION
30	NUMBER OF COINS REQUIRED TO PLAY
31	NUMBER OF SECONDS ATTRACTION AUDIO IS ON PER ATTRACTION CYCLE (0 DISABLES ATTRACTION AUDIO)
32	NUMBER OF SECONDS ATTRACTION AUDIO IS OFF PER ATTRACTION CYCLE
33	SPINNER#1 MINIMUM SPINNER SPEED TO ENABLE SLOW/FAST STOP BUTTONS WHEN RAMPING SPEED UP (INCREMENTS OF 10)
34	SPINNER#2 MINIMUM SPINNER SPEED TO ENABLE SLOW/FAST STOP BUTTONS WHEN RAMPING SPEED UP (INCREMENTS OF 10)
35	SPINNER#3 MINIMUM SPINNER SPEED TO ENABLE SLOW/FAST STOP BUTTONS WHEN RAMPING SPEED UP (INCREMENTS OF 10)
36	SPINNER#4 MINIMUM SPINNER SPEED TO ENABLE SLOW/FAST STOP BUTTONS WHEN RAMPING SPEED UP (INCREMENTS OF 10)
37	SPINNER#5 MINIMUM SPINNER SPEED TO ENABLE SLOW/FAST STOP BUTTONS WHEN RAMPING SPEED UP (INCREMENTS OF 10)
38	SPINNER#1 MINIMUM SPINNER SPEED TO ENABLE FAST STOP BUTTONS WHEN RAMPING SPEED DOWN (INCREMENTS OF 10)
39	SPINNER#2 MINIMUM SPINNER SPEED TO ENABLE FAST STOP BUTTONS WHEN RAMPING SPEED DOWN (INCREMENTS OF 10)
40	SPINNER#3 MINIMUM SPINNER SPEED TO ENABLE FAST STOP BUTTONS WHEN RAMPING SPEED DOWN (INCREMENTS OF 10)
41	SPINNER#4 MINIMUM SPINNER SPEED TO ENABLE FAST STOP BUTTONS WHEN RAMPING SPEED DOWN (INCREMENTS OF 10)
42	SPINNER#5 MINIMUM SPINNER SPEED TO ENABLE FAST STOP BUTTONS WHEN RAMPING SPEED DOWN (INCREMENTS OF 10)
43	SPINNER#1 MAXIMUM RPM (INCREMENTS OF 25)
44	SPINNER#2 MAXIMUM RPM (INCREMENTS OF 25)
45	SPINNER#3 MAXIMUM RPM (INCREMENTS OF 25)
46	SPINNER#4 MAXIMUM RPM (INCREMENTS OF 25)
47	SPINNER#5 MAXIMUM RPM (INCREMENTS OF 25)
48	SPINNER MAXIMUM TIME. THE TIME IN SECONDS BEFORE POWER IS REMOVED FROM SPINNER MOTOR (INCREMENTS OF 5)
49	SPIN UNTIL YOU WIN 0=COMPLEX GAME PLAY 1=SPIN UNTIL PLAYER GETS POINTS
50	MAXIMUM NUMBER SPINS (INCREMENTS OF 1)
51	FAST STOP PUMPING IS ENABLED WHEN SET TO 1
52	NUMBER OF POINTS REQUIRED PER TICKET DISPENSED (INCREMENTS OF 1)
53	SPINNER TIMEOUT IF PLAYER DOES NOT PUSH START BUTTON (INCREMENTS OF 1)
54	MUST PAY TO GO HIGHER 0 = START SPINNER HIGHER AUTOMATIC, 1 = PLAYER MUST USE A CREDIT TO GO HIGHER
55	EXTRA GAMES DISABLE. DISABLE EXTRA GAMES FOR HIGHER AMOUNTS OF COINS DEPOSITED (1 = DISABLE EXTRA GAME, 0 = ENABLE)
56	DEMO MODE 0 = NOT DEMO MODE 1 = DEMO MODE

Changing or Viewing Miscellaneous Settings

STEP #	DESCRIPTION
57	ENABLE KEYPAD DISPLAY 0 = DO NOT ENABLE KEYPAD IN GAME MODE 1 = ENABLE KEYPAD IN GAME MODE
58	DISABLE GOING UP SOUND 0 = PLAY GOING UP SOUND 1 = DO NOT PLAY GOING UP SOUN
59	PLAY INSTRUCTIONS DURING ATTRACTION 0 – DO NOT PLAY INSTRUCTION SOUNDS 1 – PLAY INSTRUCTION SOUNDS
60	TIMEOUT TO GO HIGHER TIME IN SECONDS BEFORE GAME ENDS IF PLAYER DOES NOT SELECT OPTION TO GO HIGHER
61	SPINNER DIAGNOSTIC SENSITIVITY LEVEL 0 – 9 0 = MOST SENSITIVE 9 = LEAST SENSITIVE

RESETTING THE STATISTICS

Pressing the **START BUTTON** will execute the reset.

STEP #	DESCRIPTION
70	RESET STATISTICS

Running Diagnostics Steps 71 – 79 And 99

DIAGNOSTICS 71 – 75

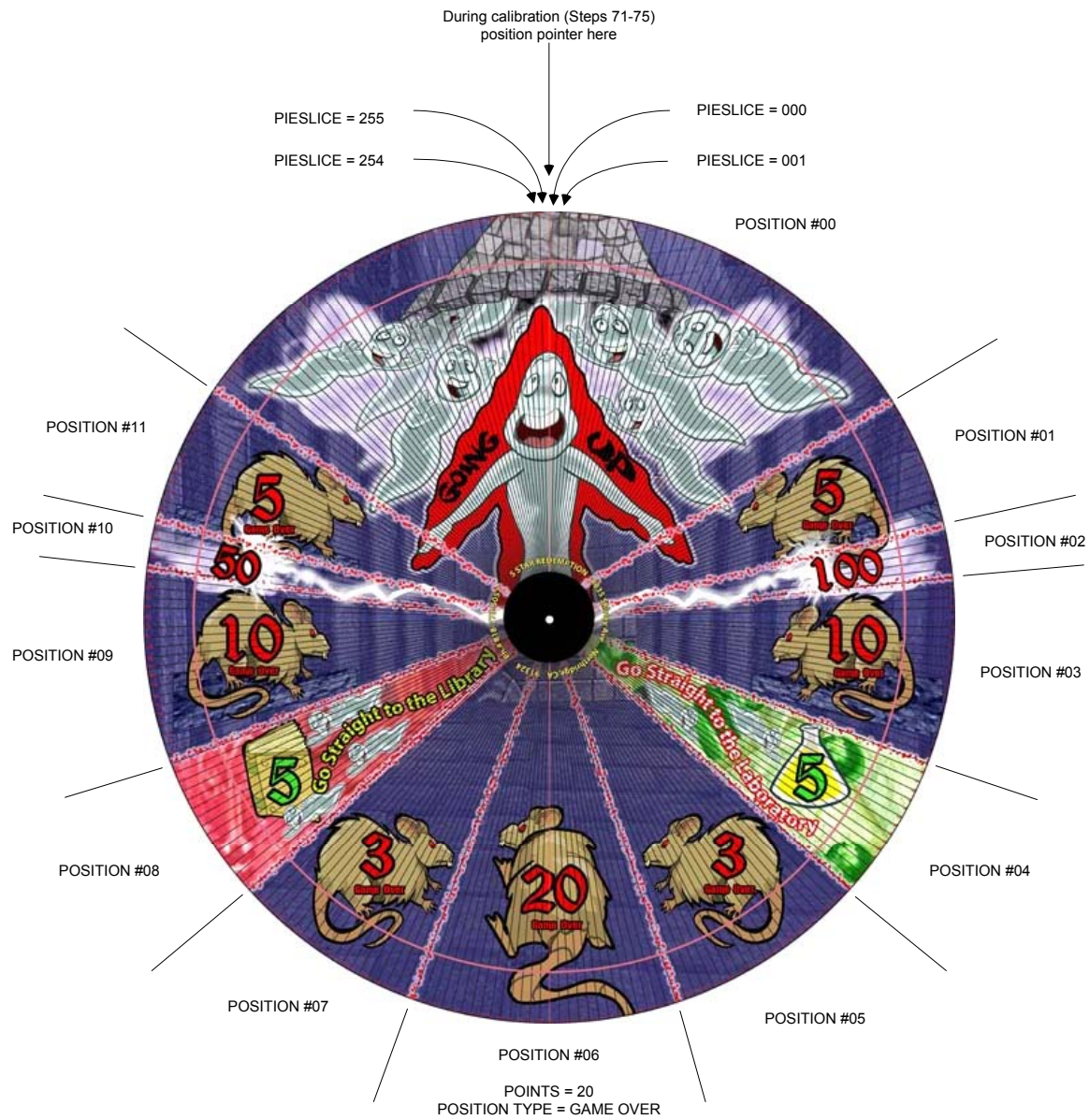

Diagnostic 71- 75 Position Type & Pie Slice Definition

Running Diagnostics Steps 71 – 79 And 99

HOW TO RUN DIAGNOSTICS 71 – 75 CALIBRATING SPINNERS

Displays Spinner Information Pie Slices 0-255, Position Type, Points, and Position Number.
Pressing the **START BUTTON** will execute the **Calibration of the Spinner**.

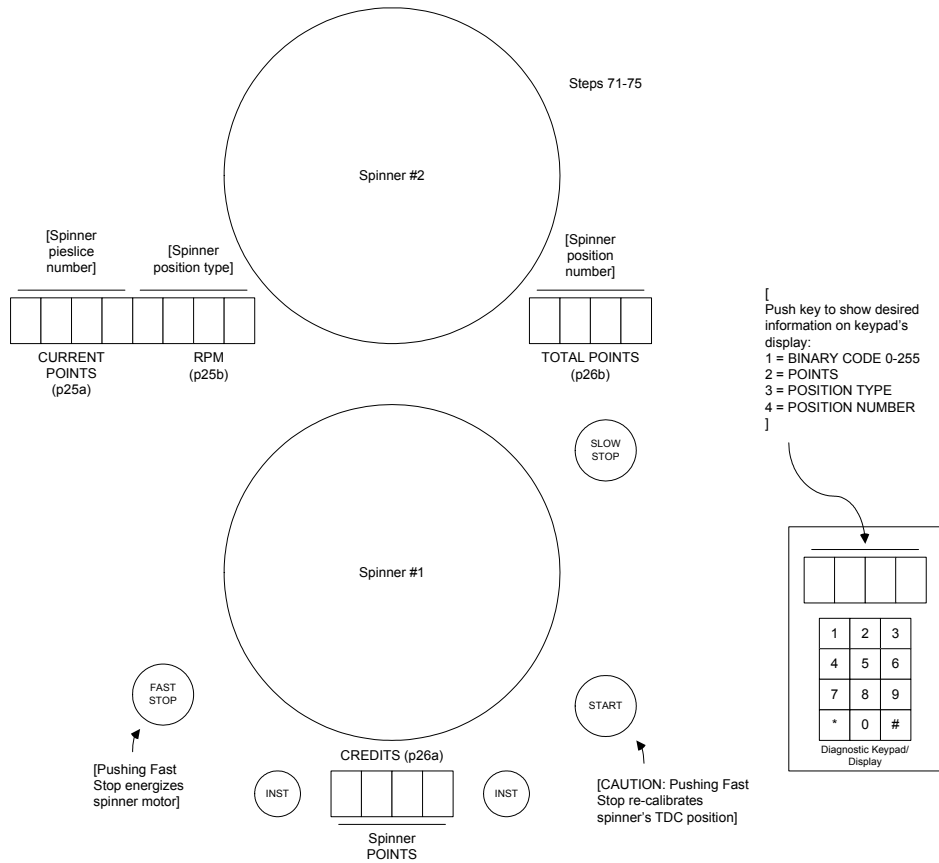

Step's 71 – 75 Diagnostic Layout

Troubleshooting Steps for Diagnostics 71 - 75

Problem	Solution
Pie Slice is not zero when spinner is pointing straight up to TDC (top dead center)	<ul style="list-style-type: none"> Recalibrate to TDC by manually positioning pointer straight up and pushing Start button (spinner may be energized by momentarily pushing Fast Stop pushbutton)
Wrong Pie Slice 0-255, Pie Slice number should increase smoothly from 0 to 255 as spinner is rotated clockwise	<ul style="list-style-type: none"> Verify spinner board switches are set correctly Examine/reseat wiring harness connections to spinner board
Wrong Position Number, Position Number should increase smoothly from 0 as spinner is rotated clockwise through each Spinner Position	<ul style="list-style-type: none"> Verify spinner board switches are set correctly Examine/reseat wiring harness connections to spinner board Recalibrate to TDC (top dead center) by manually positioning pointer straight up and pushing Fast Stop button

Running Diagnostics Steps 71 – 79 And 99

RUNNING DIAGNOSTICS 76

Checking Spinner Motor, and Brake

Push **Left Instruction Pushbutton** to select desired spinner to test. The number of the selected spinner is shown on the RPM display. Push the **Fast Stop Pushbutton** to energize the spinner brake and the **Start Pushbutton** to energize the spinner motor. Hold down the **Slow Stop Pushbutton** while pushing the **Start Pushbutton** to cause the spinner to spin more slowly. Perform the troubleshooting steps in the sequence specified in Troubleshooting Steps for Diagnostic 76 on next page.

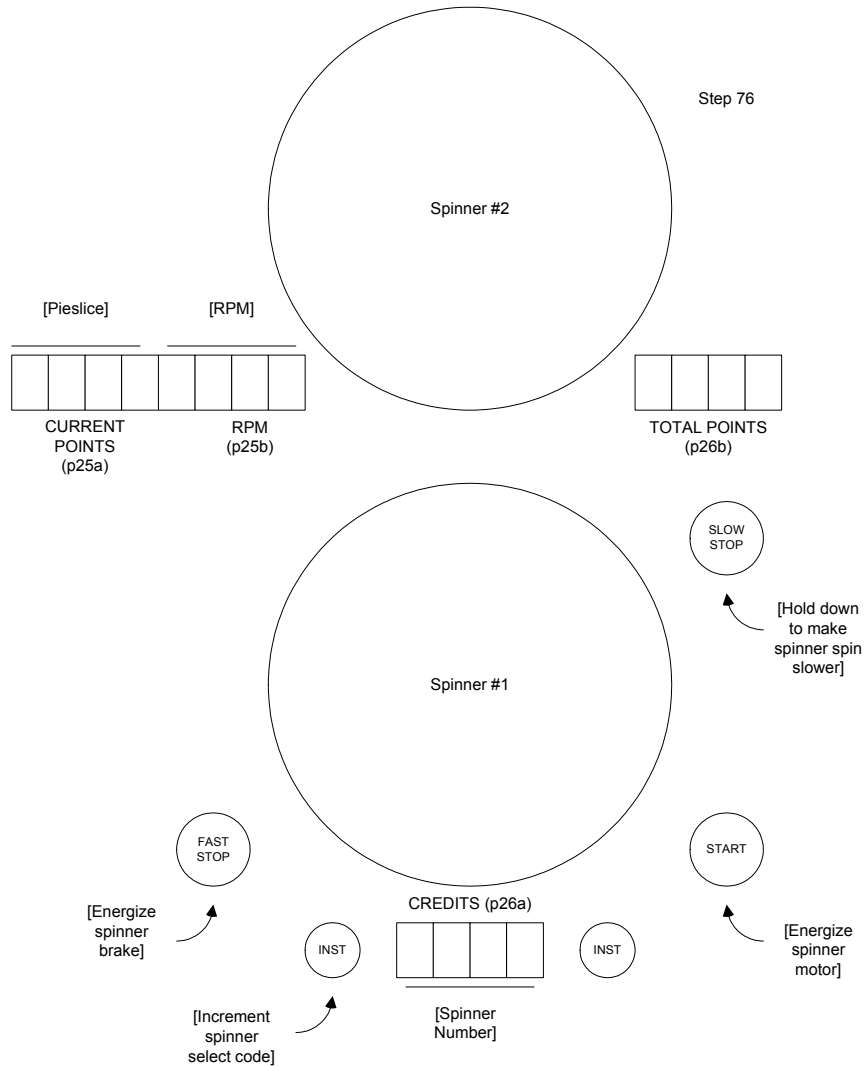

Step 76 Diagnostic Layout

Running Diagnostics Steps 71 – 79 And 99

TROUBLESHOOTING STEPS FOR DIAGNOSTIC 76

Problem	Solution
Particular spinner(s) do not spin	<ul style="list-style-type: none"> • Verify spinner board switches are set correctly • Examine/reseat wiring harness connections to spinner boards • Swap spinner boards to see if problem moves with the boards and replace any spinner board found to be defective (be sure board switches are set correctly) • Replace spinner motor and retest
Particular brake(s) do not activate	<ul style="list-style-type: none"> • Verify spinner board switches are set correctly • Examine/reseat wiring harness connections to spinner boards • Swap spinner boards to see if problem moves with the boards and replace any spinner board found to be defective (be sure board switches are set correctly) • Adjust/replace spinner brake and retest
All spinners do not spin	<ul style="list-style-type: none"> • Examine/reseat wiring harness connections to spinner boards • Look for low-voltage changes at VTmux board output when spinner should be spinning and if voltage does not change, replace VTmux board and retest
All brakes do not activate	<ul style="list-style-type: none"> • Examine/reseat wiring harness connections to spinner boards • Look for low-voltage changes at VTmux board output when brake should be activated and if voltage does not change, replace VTmux board and retest

RUNNING DIAGNOSTICS 77

Display Keypad Inputs

Push each of the individual numbers on the keypad to display the associated keypad number.

RUNNING DIAGNOSTICS 78

Testing Ticket Dispenser

Push the Flashing **Call Attendant Pushbutton** to Dispense a Single Ticket.

Troubleshooting Steps for Diagnostic 78

Problem	Solution
Does not dispense tickets	<ul style="list-style-type: none"> • Clear ticket dispenser of any jammed tickets • Load tickets if empty • Try dispensing a ticket using diagnostic mode, if ticket does not dispense: <ul style="list-style-type: none"> ○ Check wiring harness ○ Replace ticket dispenser and retest ○ Replace VTmux board and retest

Running Diagnostics Steps 71 – 79 And 99

RUNNING DIAGNOSTICS 79

Testing for Spinner Intermittent Problems

Check for spinner intermittent problems while spinners are spinning. Momentarily press keypad 1-5 to begin test on selected spinner. **Press Keypad 0** to stop test. Perform the troubleshooting steps in the sequence Troubleshooting Steps for Diagnostic 79.

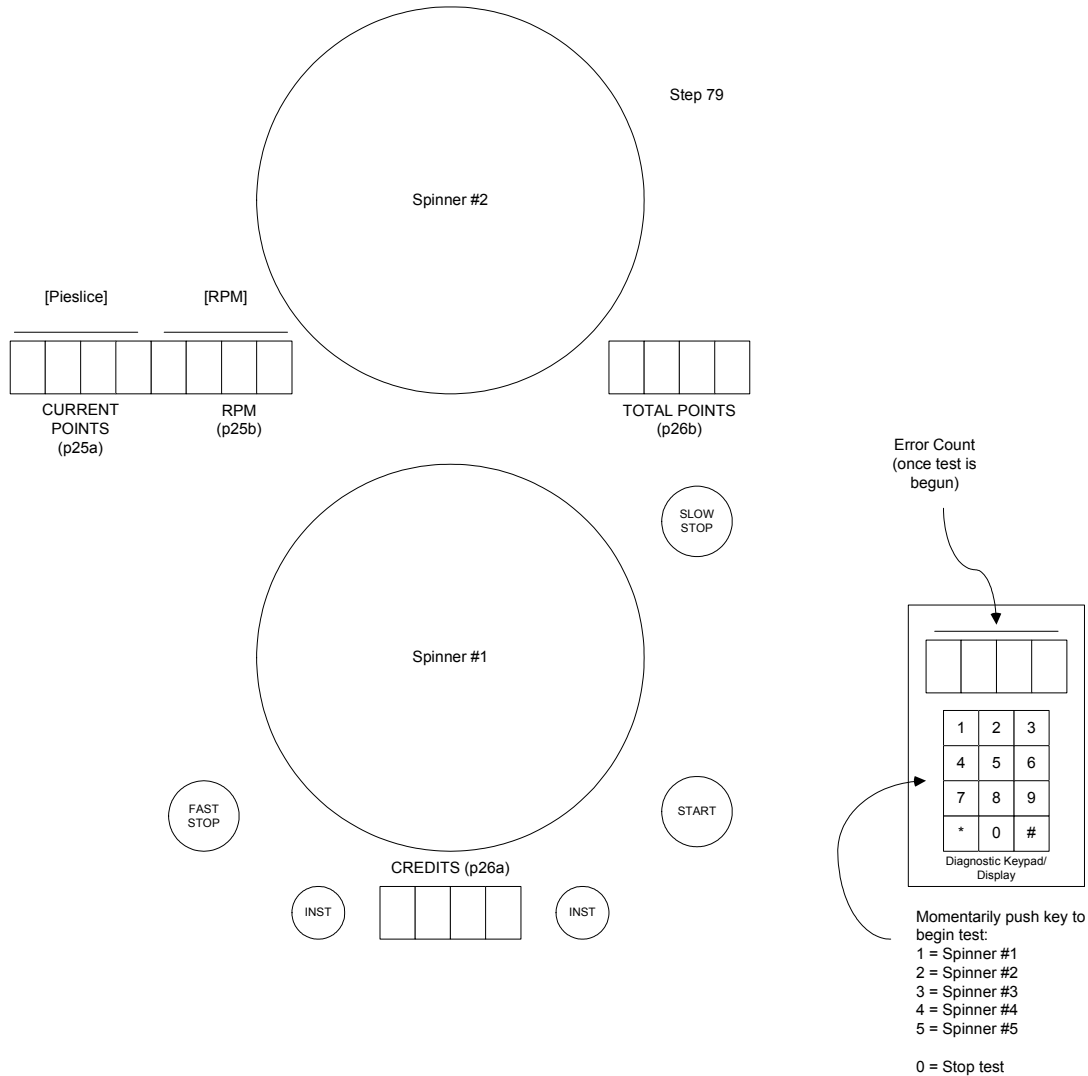

Step 79 Diagnostic Layout

Troubleshooting Steps for Diagnostic 79

Problem	Solution
Spinner errors detected (a couple errors during a couple minutes of operation is normal and will not cause problems in game's operation)	<ul style="list-style-type: none"> • Examine/reseat wiring harness connections to spinner boards • Replace spinner board and retest • Replace spinner mechanism and retest

Running Diagnostics Steps 71 – 79 And 99

STEP 99 VIEWING SOFTWARE IDENTIFICATION

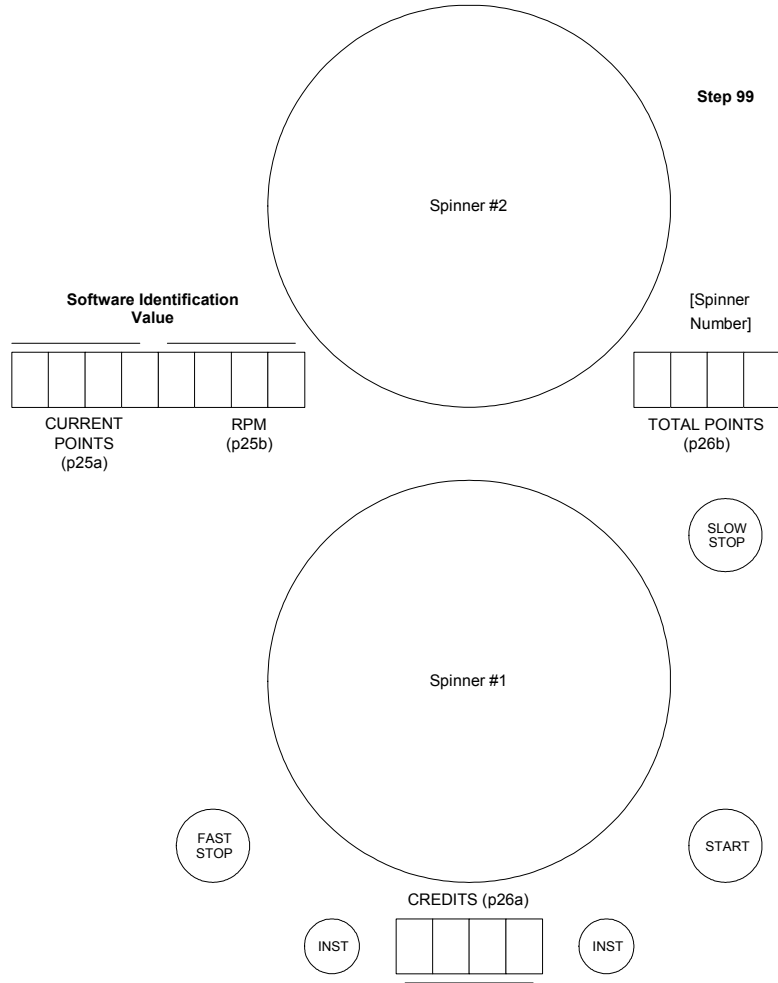

STEP #	DESCRIPTION
99	VIEW EIGHT DIGIT SOFTWARE IDENTIFICATION

View and Changing Spinner Target Values

VIEWING AND CHANGING SPINNER TARGET VALUES STEPS 100 – 576

Pressing the **FAST STOP BUTTON** will decrement the Value, Pressing the **START BUTTON** will increment the value. To increase the **STEP NUMBER** use the Numeric Keypad and press the ‘*’, to decrease the **STEP NUMBER** press the ‘#’ symbol. To Go to **STEPS** directly Hold down the “*” key while entering the **STEP NUMBER** in the keypad. Pressing the *Program Mode* or Holding Down both the ‘*’ and “#” symbols will allow the operator to exit. The program button is located near the main board inside of the cabinet.

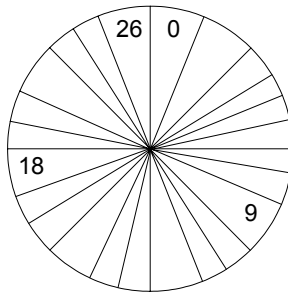

STEPS 100 - 126

VIEWING SPINNER #1 TARGET POINTS

STEP NUMBER SPINNER #1	SPINNER POSITION	TARGET POINTS
100	0	INCREMENTS OF 1
101	1	“
102	2	“
103	3	“
104	4	“
105	5	“
106	6	“
107	7	“
108	8	“
109	9	“
110	10	“
111	11	“
112	12	“
113	13	“
114	14	“
115	15	“
116	16	“
117	17	“
118	18	“

119	19	“
STEP NUMBER SPINNER #1	SPINNER POSITION	TARGET POINTS
120	20	“
121	21	“
122	22	“
123	23	“
124	24	“
125	25	“
126	26	“

View and Changing Spinner Target Values

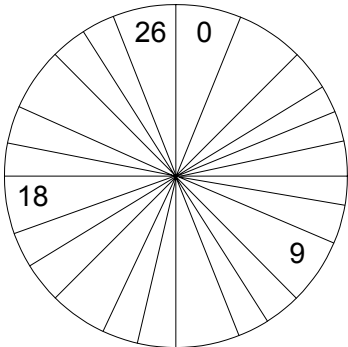

**STEPS 150 - 176
CHANGING SPINNER #1 TARGET TYPES**

STEP NUMBER SPINNER #1	SPINNER POSITION	TARGET TYPES
150	0	0=NONE 1-5 JUMP TO SPINNER# 6=UP 7 = DOWN 8= DEATH
151	1	“
152	2	“
153	3	“
154	4	“
155	5	“
156	6	“
157	7	“
158	8	“
159	9	“
160	10	“
161	11	“
162	12	“
163	13	
164	14	
165	15	
166	16	
167	17	
168	18	
169	19	
170	20	
171	21	
172	22	
173	23	
174	24	
175	25	
176	26	

View and Changing Spinner Target Values

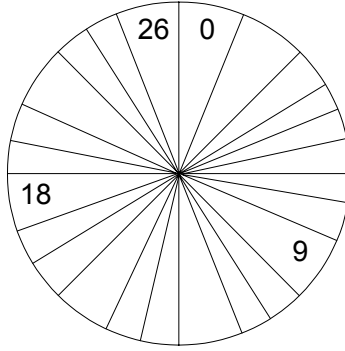

STEPS 200 - 226

VIEWING SPINNER #2 TARGET POINTS

STEP NUMBER SPINNER #1	SPINNER POSITION	TARGET POINTS
200	0	INCREMENTS OF 5
201	1	“
202	2	“
203	3	“
204	4	“
205	5	“
206	6	“
207	7	“
208	8	“
209	9	“
210	10	“
211	11	“
212	12	“
213	13	“
214	14	“
215	15	“
216	16	“
217	17	“
218	18	“
219	19	“
220	20	“
221	21	“
222	22	“
223	23	“
224	24	“
225	25	“
226	26	“

View and Changing Spinner Target Values

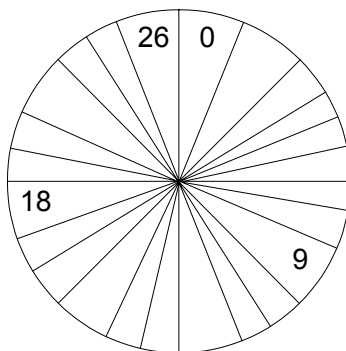

STEPS 250 - 276 CHANGING SPINNER #2 TARGET TYPES

STEP NUMBER SPINNER #1	SPINNER POSITION	TARGET TYPES
250	0	0=NONE 1-5 JUMP TO SPINNER# 6=UP 7 = DOWN 8= DEATH 9=DEAD ZONE 10= UP DEAD ZONE
251	1	“
252	2	“
253	3	“
254	4	“
255	5	“
256	6	“
257	7	“
258	8	“
259	9	“
260	10	“
261	11	“
262	12	“
263	13	“
264	14	“
265	15	“
266	16	“
267	17	“
268	18	“
269	19	“
270	20	“
271	21	“
272	22	“
273	23	“
274	24	“
275	25	“
276	26	“

View and Changing Spinner Target Values

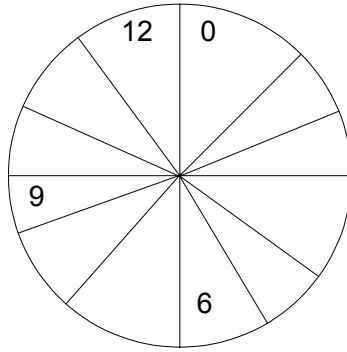

STEPS 300 - 312 CHANGING SPINNER #3 TARGET POINTS

STEP NUMBER SPINNER #1	SPINNER POSITION	TARGET POINTS
300	0	INCREMENTS OF 1
301	1	“
302	2	“
303	3	“
304	4	“
305	5	“
306	6	“
307	7	“
308	8	“
309	9	“
310	10	“
311	11	“
312	12	“

View and Changing Spinner Target Values

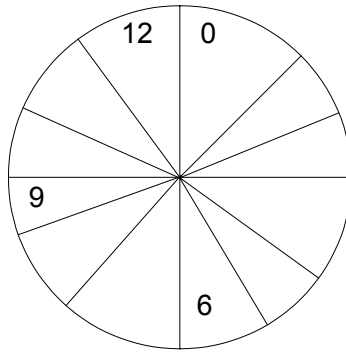

STEPS 350 - 362 CHANGING SPINNER #1 TARGET TYPES

STEP NUMBER SPINNER #1	SPINNER POSITION	TARGET TYPES
350	0	0=NONE 1-5 JUMP TO SPINNER# 6=UP 7 = DOWN 8= DEATH 9=DEAD ZONE 10= UP DEAD ZONE
351	1	“
352	2	“
353	3	“
354	4	“
355	5	“
356	6	“
357	7	“
358	8	“
359	9	“
360	10	“
361	11	“
362	12	“

View and Changing Spinner Target Values

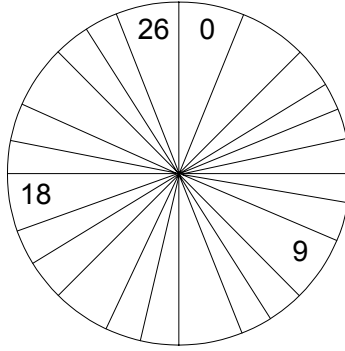

STEPS400 - 426 VIEWING SPINNER #4 TARGET POINTS

STEP NUMBER SPINNER #1	SPINNER POSITION	TARGET POINTS
400	0	INCREMENTS OF 1
401	1	“
402	2	“
403	3	“
404	4	“
405	5	“
406	6	“
407	7	“
408	8	“
409	9	“
410	10	“
411	11	“
412	12	“
413	13	“
414	14	“
415	15	“
416	16	“
417	17	“
418	18	“
419	19	“
420	20	“
421	21	“
422	22	“
423	23	“
424	24	“
425	25	“
426	26	“

View and Changing Spinner Target Values

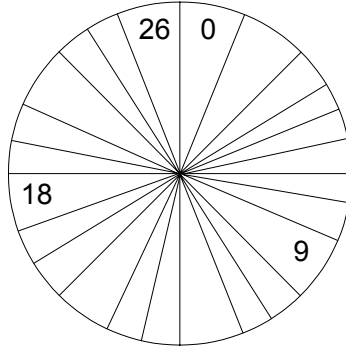

STEPS 450 - 476 CHANGING SPINNER #4 TARGET TYPES

STEP NUMBER SPINNER #1	SPINNER POSITION	TARGET TYPES
450	0	0=NONE 1-5 JUMP TO SPINNER# 6=UP 7 = DOWN 8= DEATH 9=DEAD ZONE 10= UP DEAD ZONE
451	1	“
452	2	“
453	3	“
454	4	“
455	5	“
456	6	“
457	7	“
458	8	“
459	9	“
460	10	“
461	11	“
462	12	“
463	13	“
464	14	“
465	15	“
466	16	“
467	17	“
468	18	“
469	19	“
470	20	“
471	21	“
472	22	“
473	23	“
474	24	“
475	25	“
476	26	“

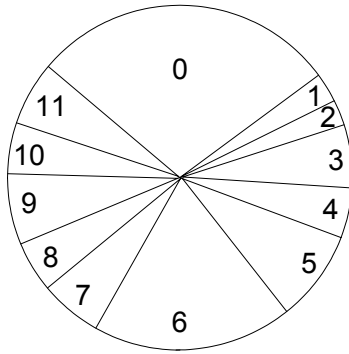

STEPS 500 - 526
VIEWING SPINNER #4 TARGET POINTS

STEP NUMBER SPINNER #1	SPINNER POSITION	TARGET POINTS
500	0	INCREMENTS OF 1
501	1	“
502	2	“
503	3	“
504	4	“
505	5	“
506	6	“
507	7	“
508	8	“
509	9	“
510	10	“
511	11	“
512	12	“
513	13	“
514	14	“
515	15	“
516	16	“
517	17	“
518	18	“
519	19	“
520	20	“
521	21	“
522	22	“
523	23	“
524	24	“
525	25	“
526	26	“

View and Changing Spinner Target Values

STEPS 550 - 576 CHANGING SPINNER #5 TARGET TYPES

STEP NUMBER SPINNER #1	SPINNER POSITION	TARGET TYPES
550	0	0=NONE 1-5 JUMP TO SPINNER# 6=UP 7 = DOWN 8= DEATH 9=DEAD ZONE 10= UP DEAD ZONE
551	1	“
552	2	“
553	3	“
554	4	“
555	5	“
556	6	“
557	7	“
558	8	“
559	9	“
560	10	“
561	11	“
562	12	“
563	13	“
564	14	“
565	15	“
566	16	“
567	17	“
568	18	“
569	19	“
570	20	“
571	21	“
572	22	“
573	23	“
574	24	“
575	25	“
576	26	“

Wiring Diagrams

Top Level Interconnections

TOP LEVEL INTERCONNECT DIAGRAM

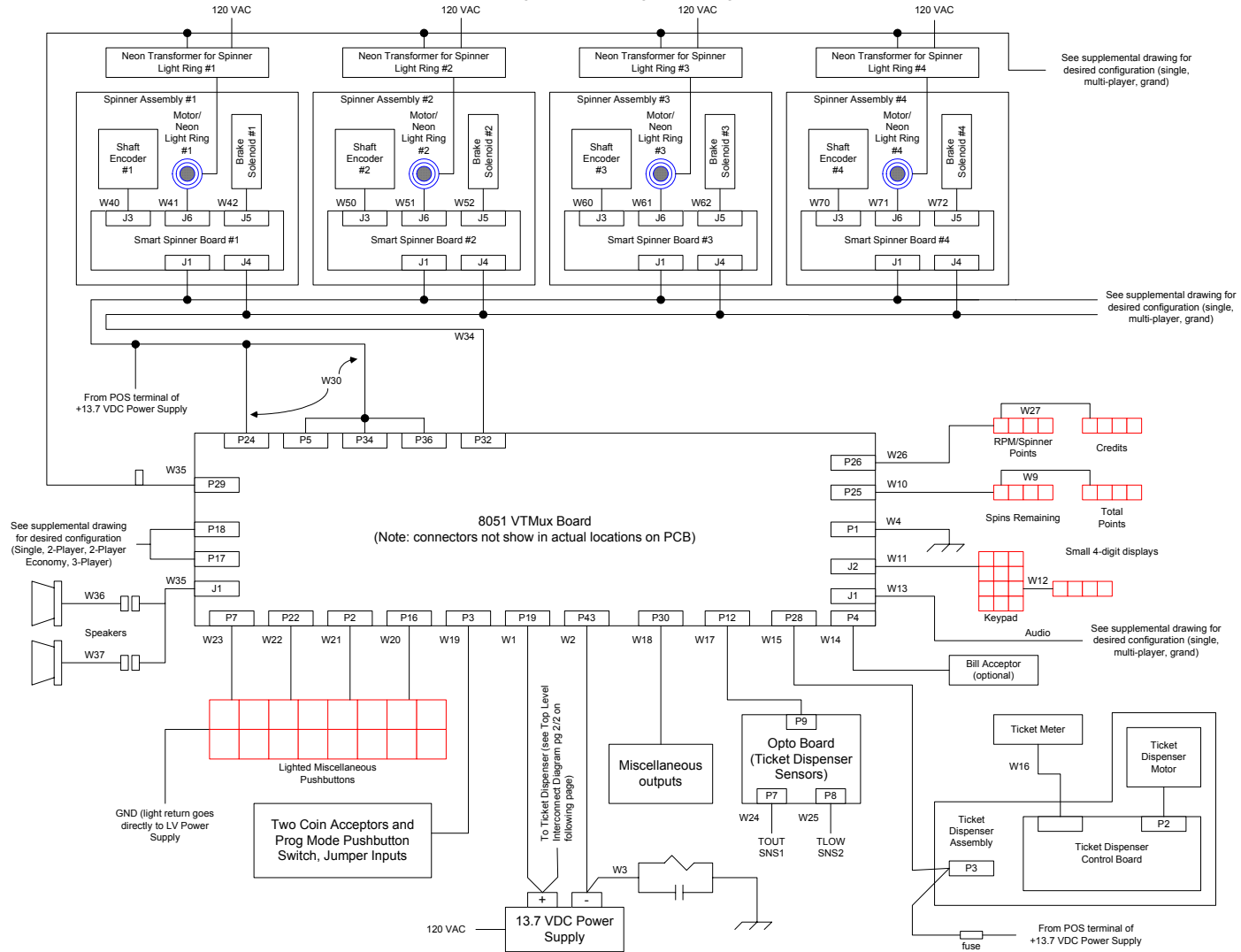
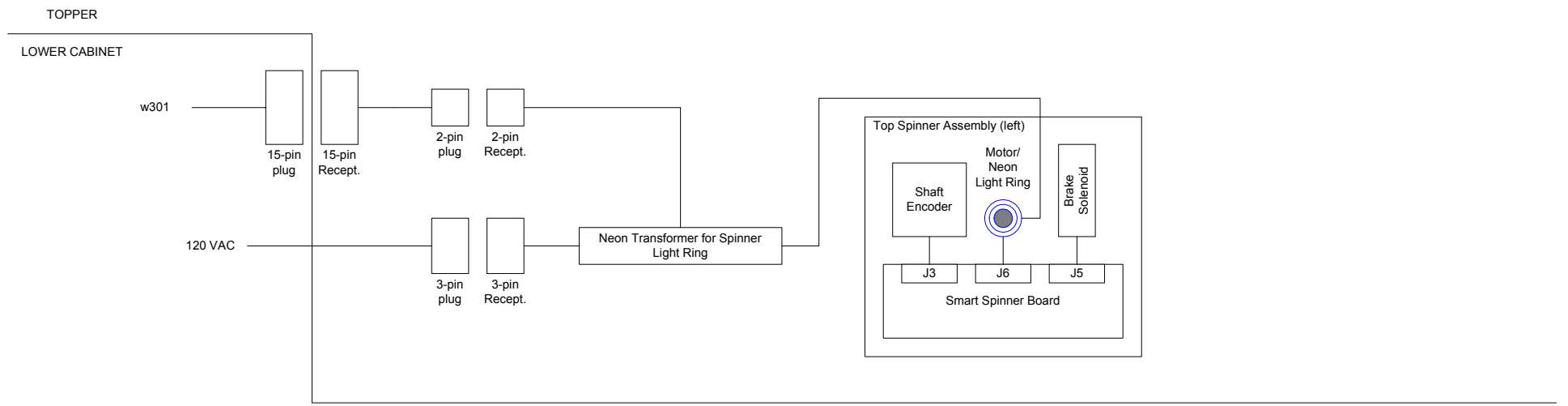
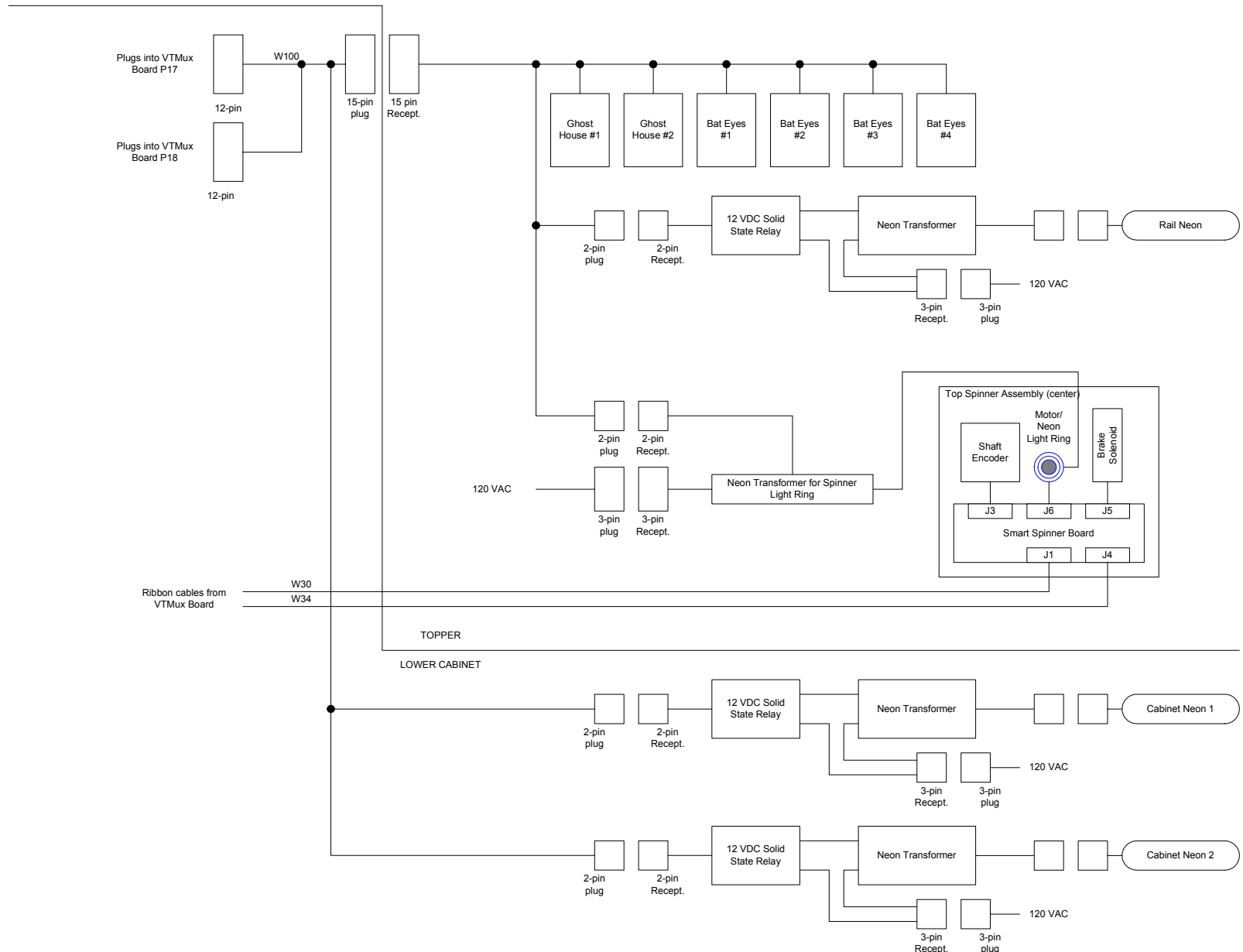

FIGURE 1 – TOP LEVEL INTERCONNECT DIAGRAM



TOP SPINNER BLOCK DIAGRAM LEFT GAME

Wiring Diagrams



TOP SPINNER BLOCK DIAGRAM CENTER GAME

Wiring Diagrams

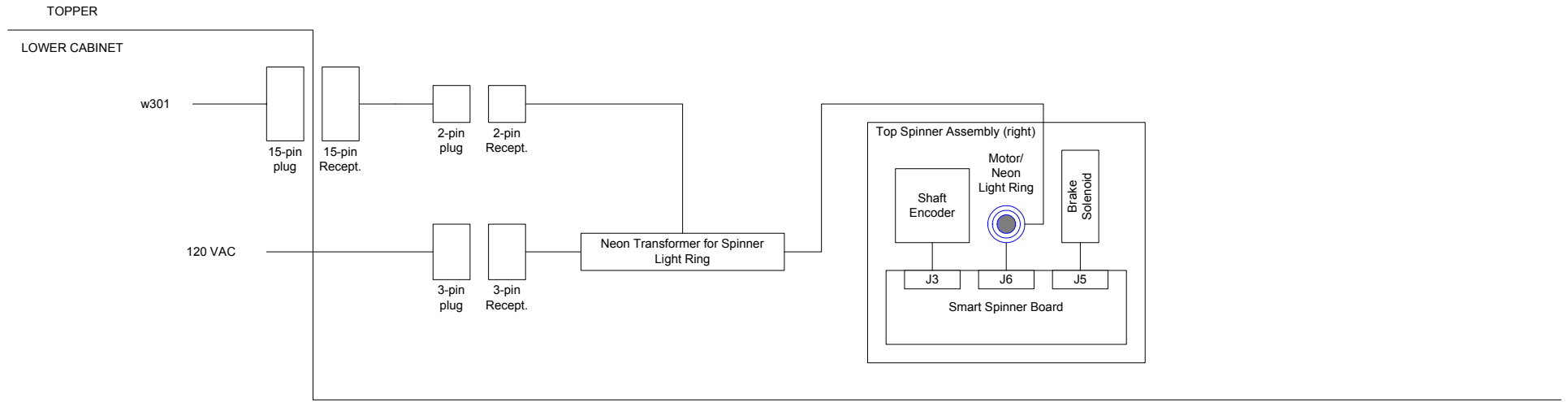

TOP SPINNER BLOCK DIAGRAM RIGHT GAME

Wiring Diagrams

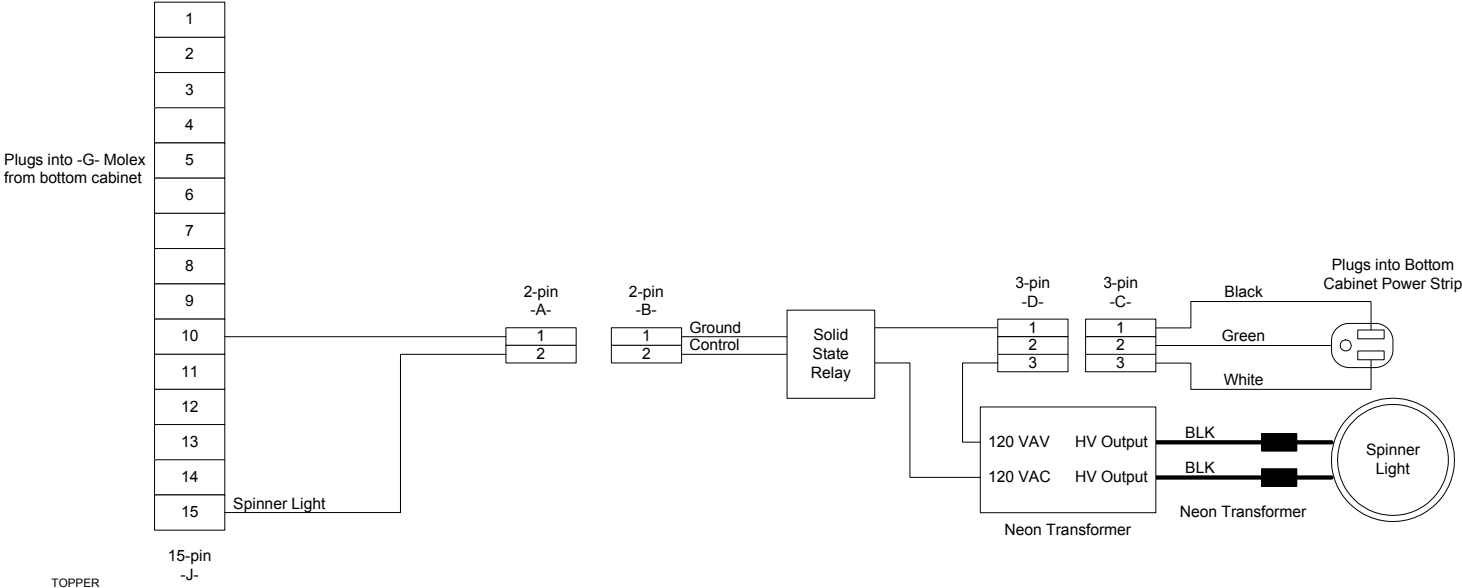

TOP SPINNER WIRING LEFT GAME

Wiring Diagrams

LOWER CABINET

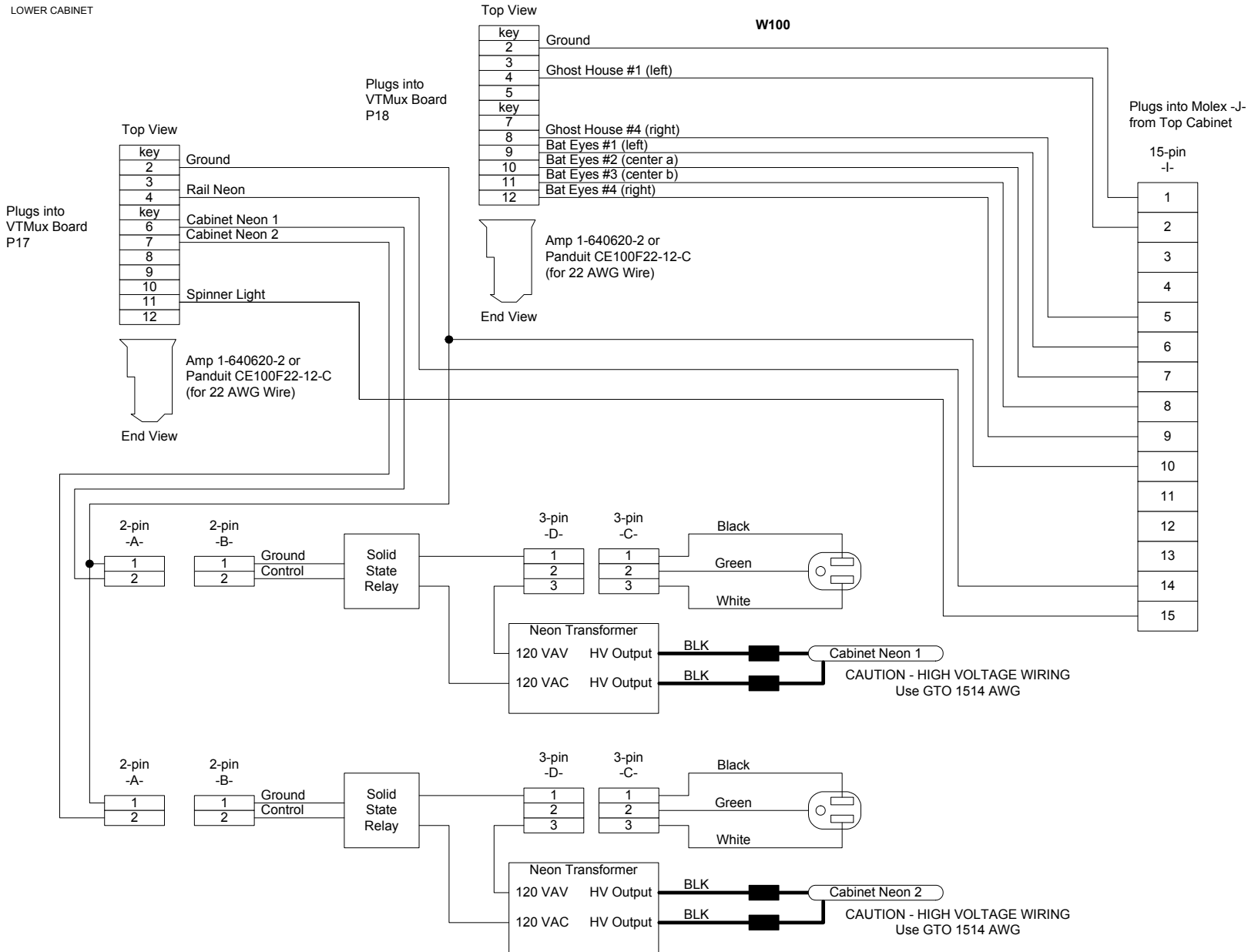

TOP SPINNER WIRING CENTER GAME

Wiring Diagrams

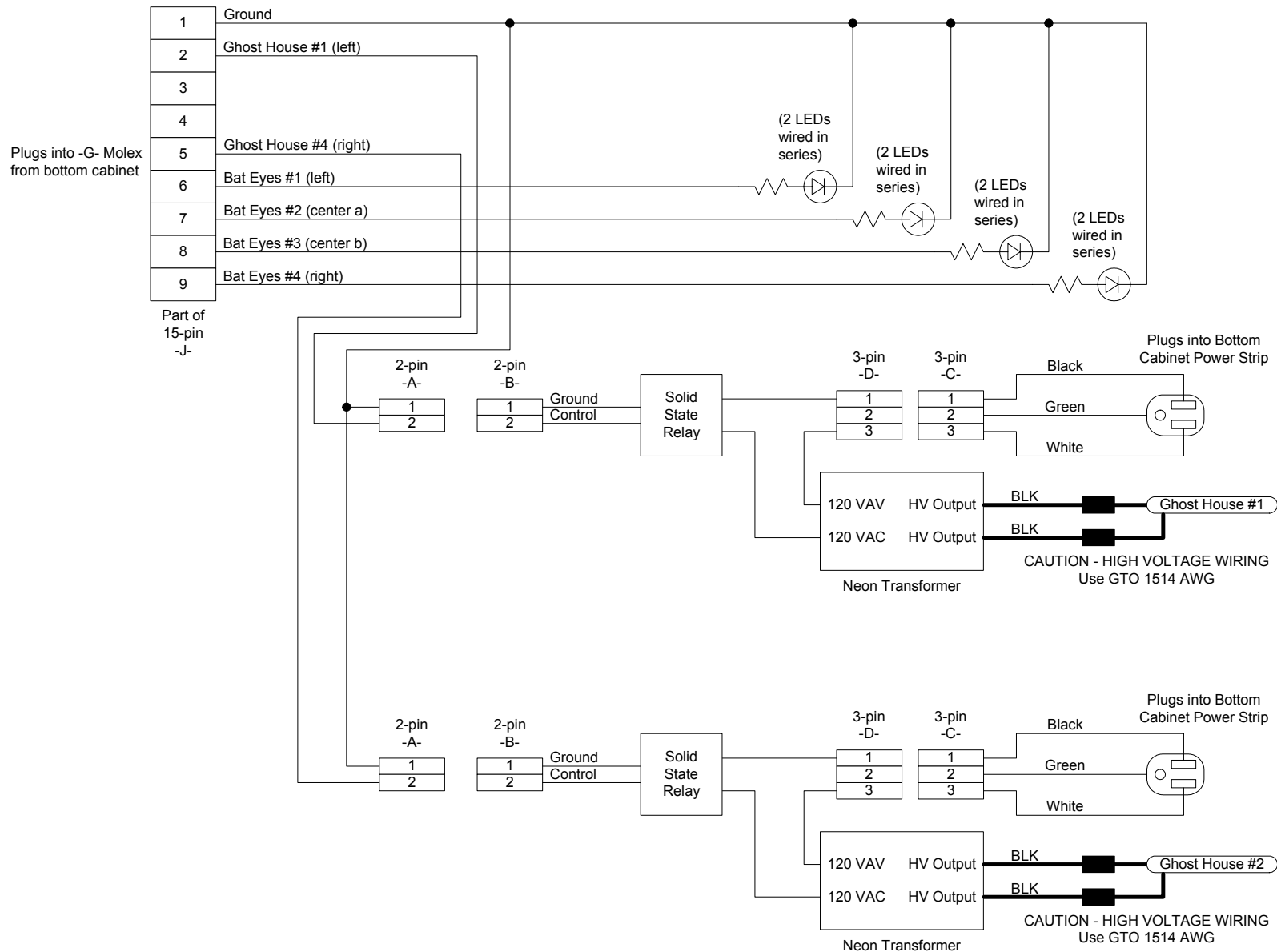

TOPPER

TOP SPINNER WIRING PINS 1-9 CENTER GAME

Wiring Diagrams

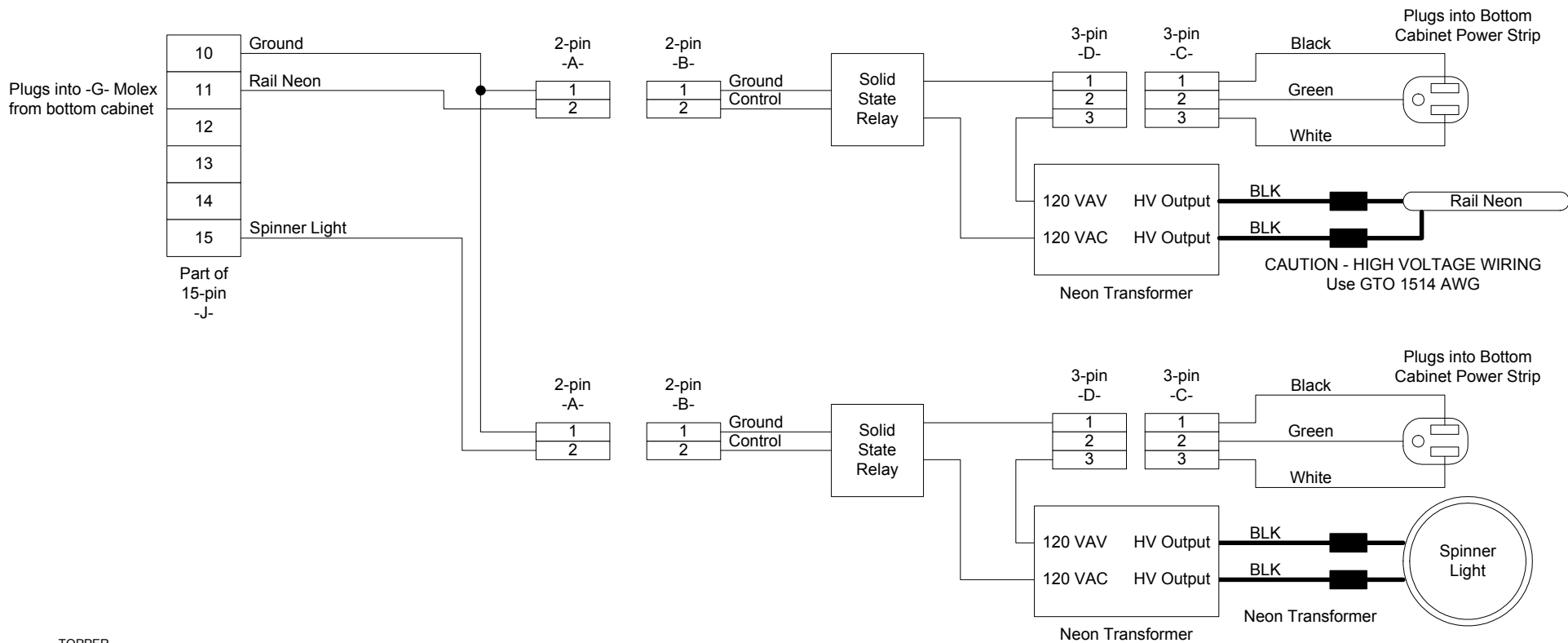

TOPPER

TOP SPINNER WIRING PINS 10-15 CENTER GAME

Wiring Diagrams

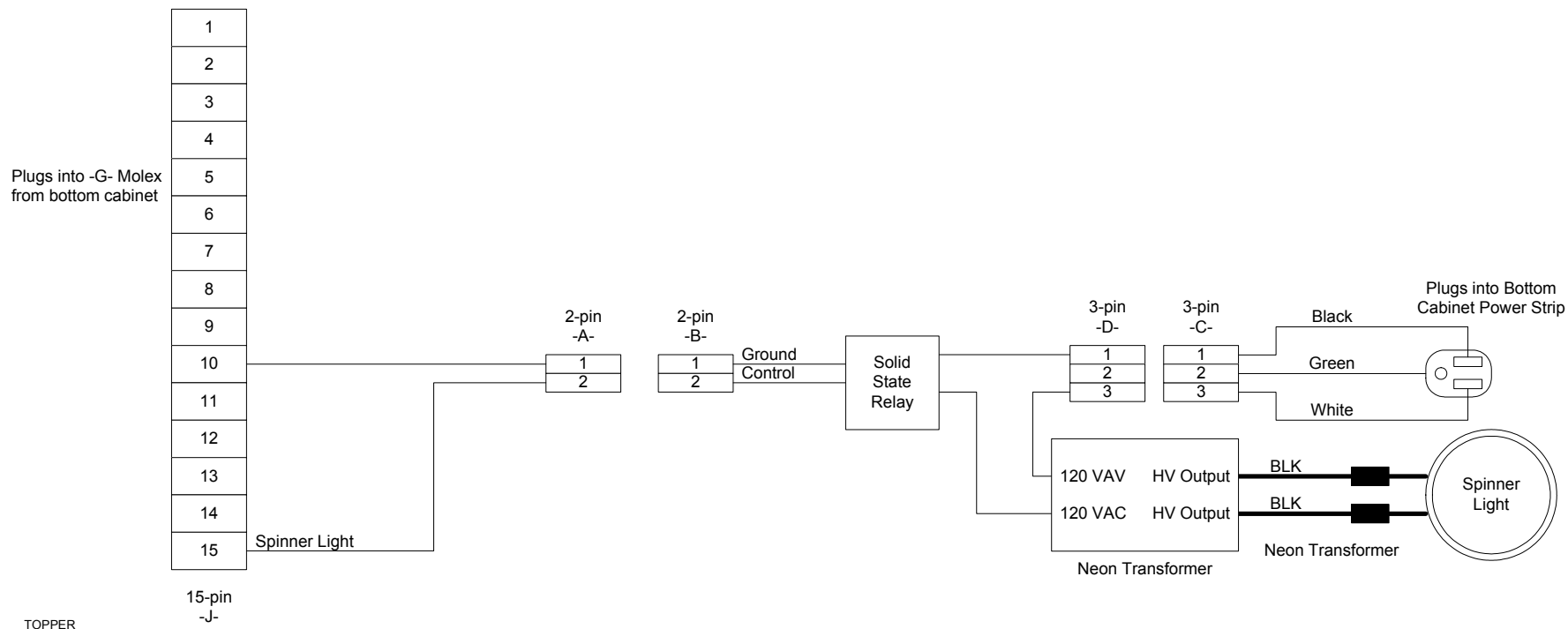

TOP SPINNER WIRING RIGHT GAME

Wiring Diagrams

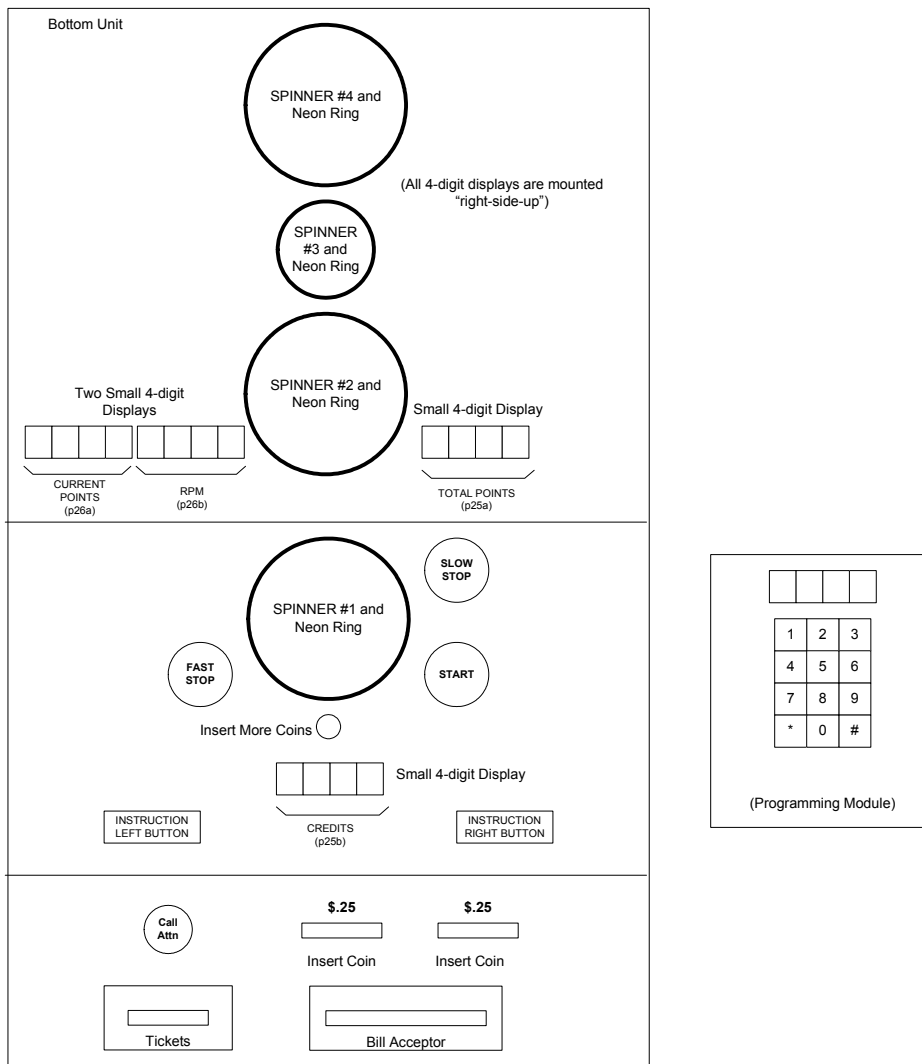

FIGURE 3 - CONTROL PANEL

Wiring Diagrams

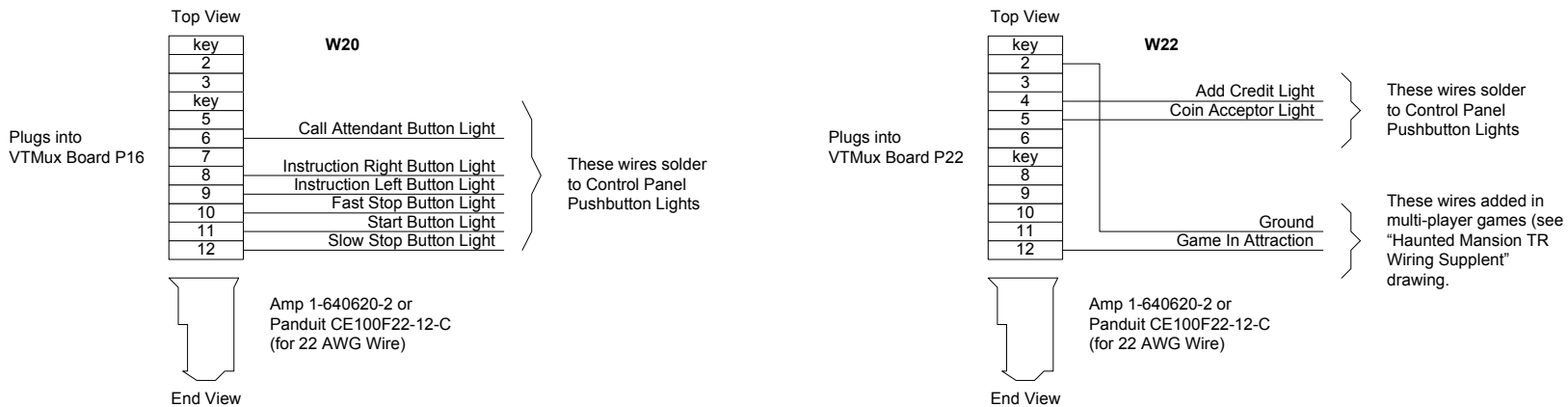

FIGURE 4 P16 & P22 CONNECTIONS FROM THE VTMUX BOARD TO THE CONTROL PANEL

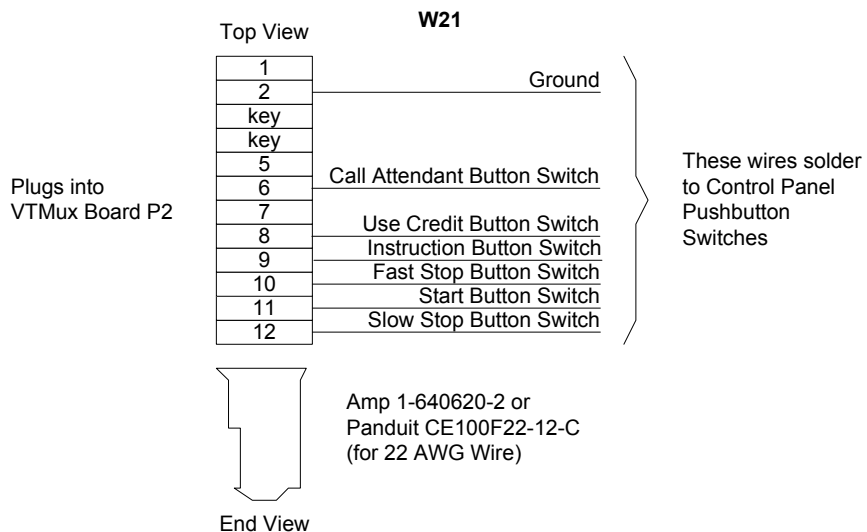

FIGURE 5 P2 CONNECTIONS FROM THE VTMUX BOARD TO THE CONTROL PANEL

Wiring Diagrams

See supplemental drawing for desired configuration (single, multi-player, grand)

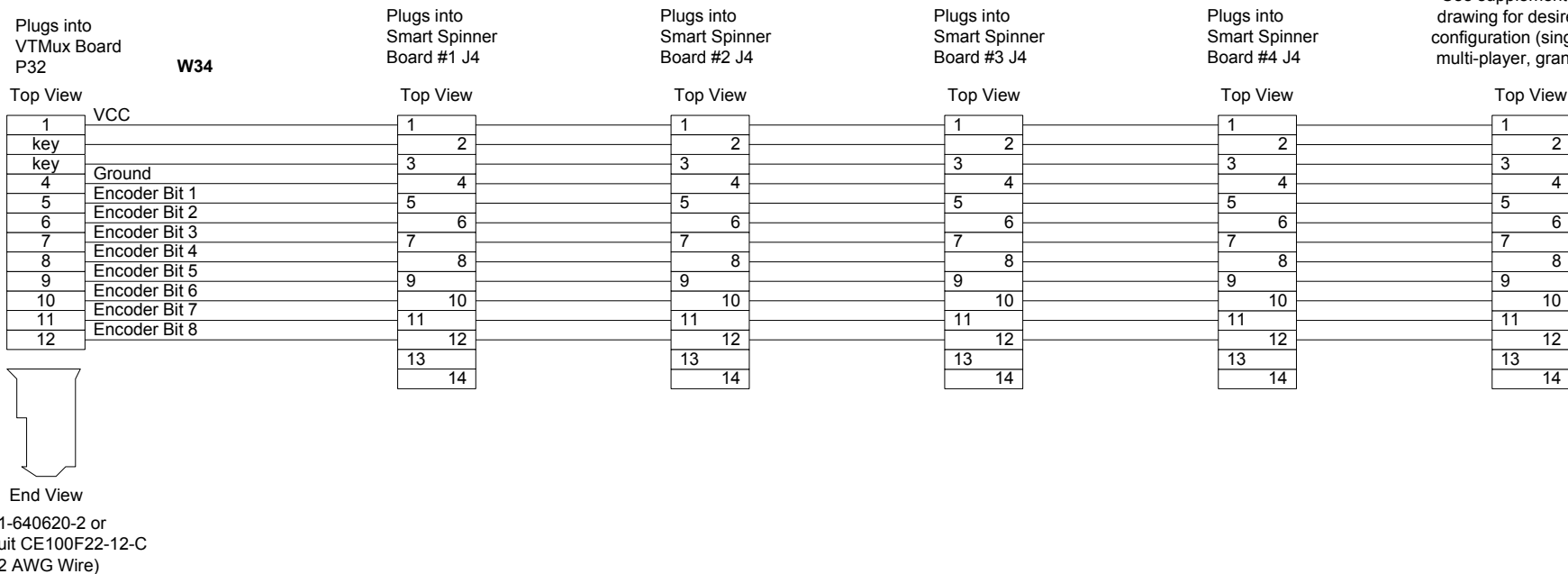

FIGURE 6 VTMUX BOARD P32 TO SMART SPINNER BOARD #1,2,3,4 J4s W34

Wiring Diagrams

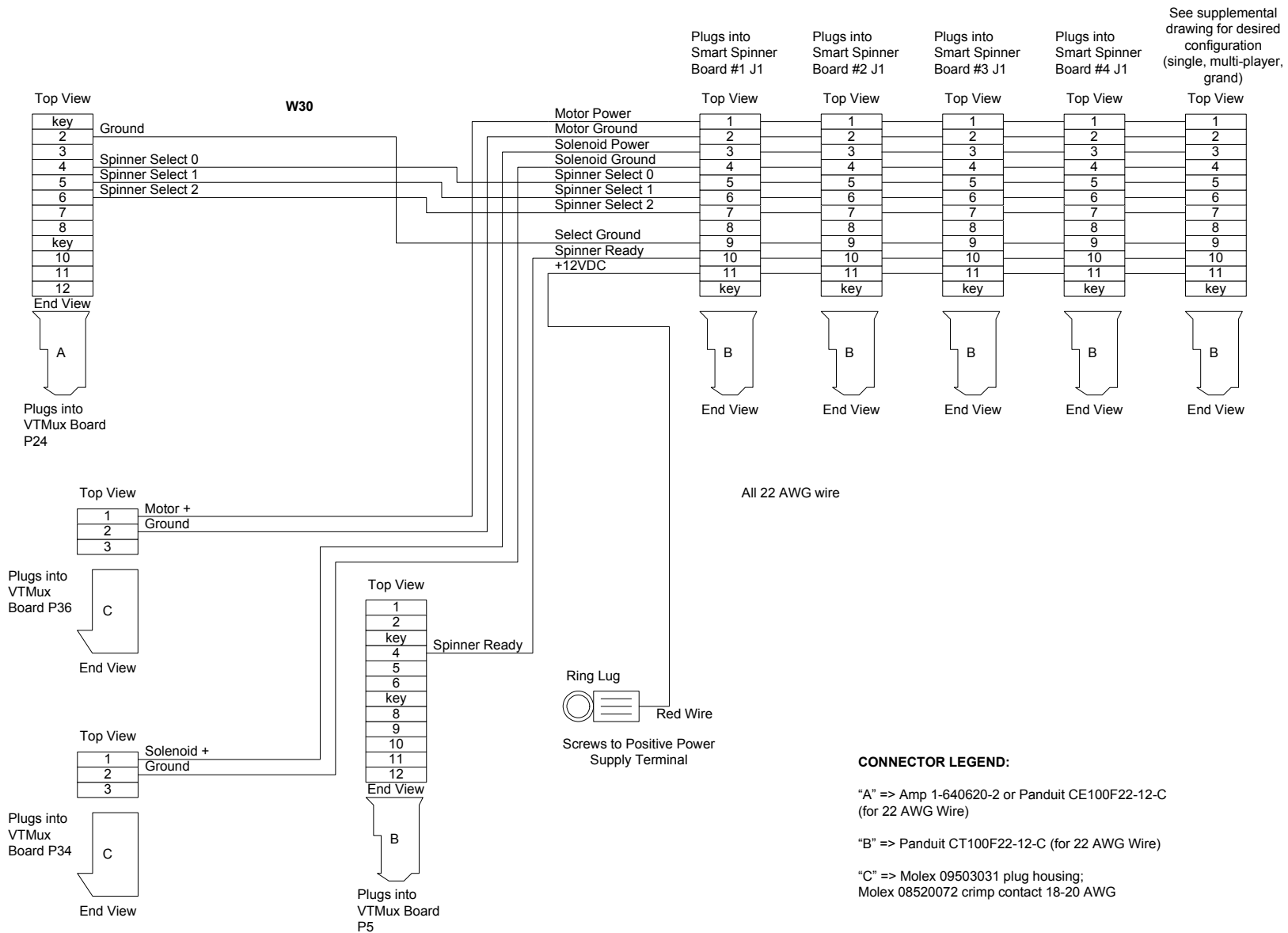

FIGURE 7 POWER SUPPLY TO SPINNER BOARDS #1-5 J1s7
W30 VTMUX BOARD P5, 24, 34, 36, AND 13.7VDC

Wiring Diagrams

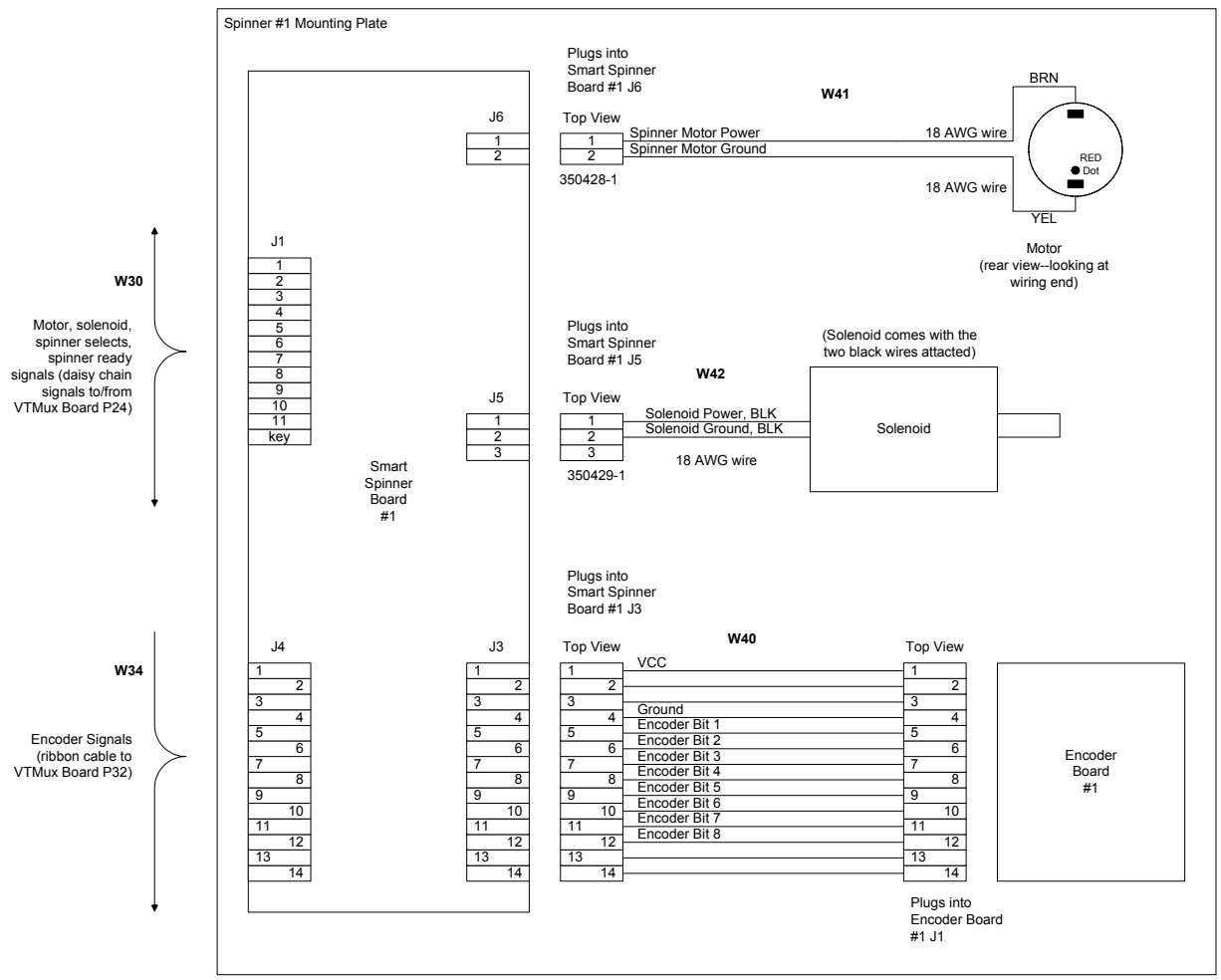

FIGURE 8 SPINNER #1 SUBASSEMBLY
W40 SPINNER BOARD #1 J3 TO ENCODER BOARD #1 J1
W41 SPINNER BOARD #1 J6 TO SPINNER MOTOR
W42 SPINNER BOARD #1 J5 TO SPINNER SOLENOID

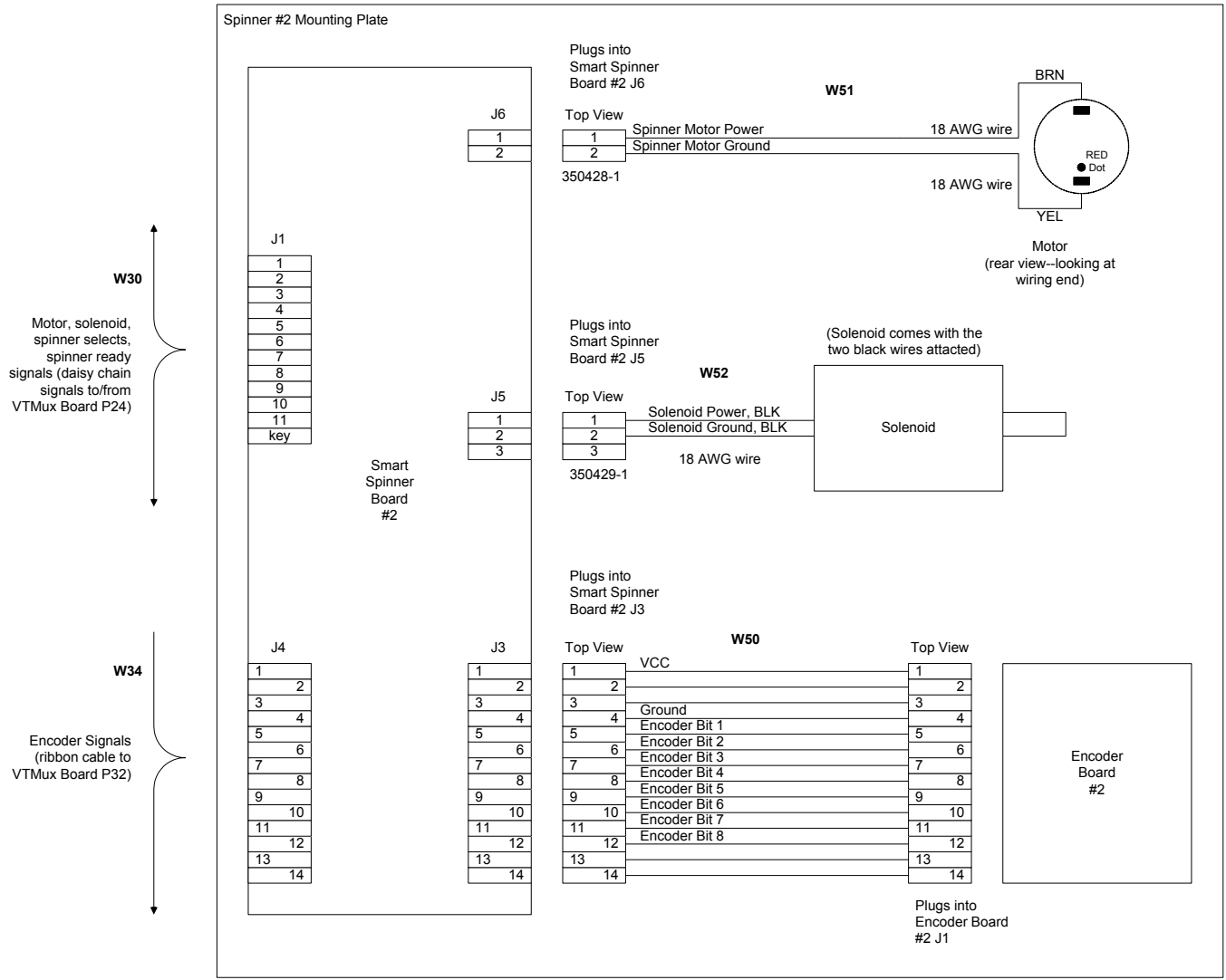

FIGURE 9 SPINNER #2 SUBASSEMBLY
W40 SPINNER BOARD #2 J3 TO ENCODER BOARD #2 J1
W41 SPINNER BOARD #2 J6 TO SPINNER MOTOR
W42 SPINNER BOARD #2 J5 TO SPINNER SOLENOID

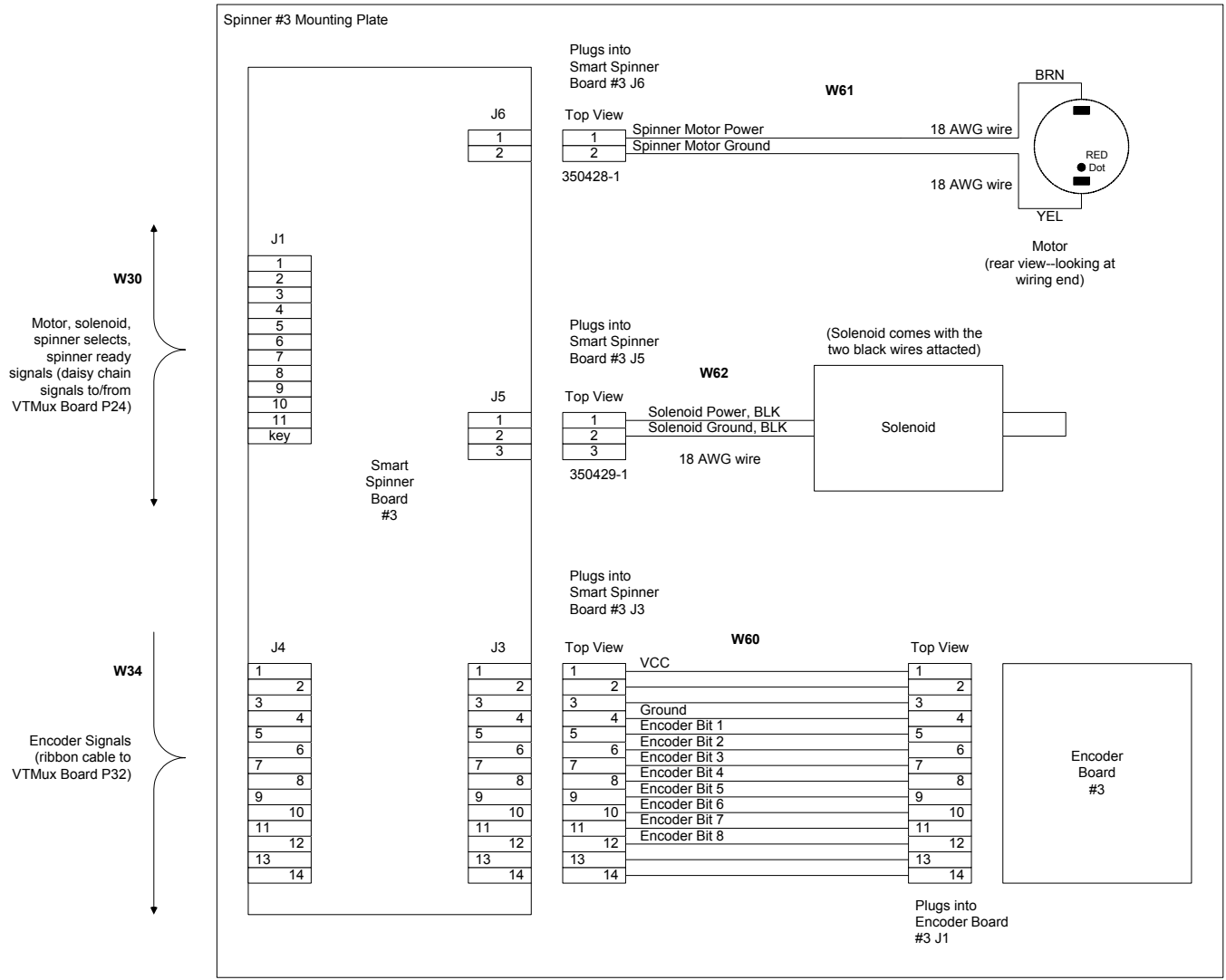

FIGURE 10 SPINNER #3 SUBASSEMBLY
W40 SPINNER BOARD #3 J3 TO ENCODER BOARD #3 J1
W41 SPINNER BOARD #3 J6 TO SPINNER MOTOR
W42 SPINNER BOARD #3 J5 TO SPINNER SOLENOID

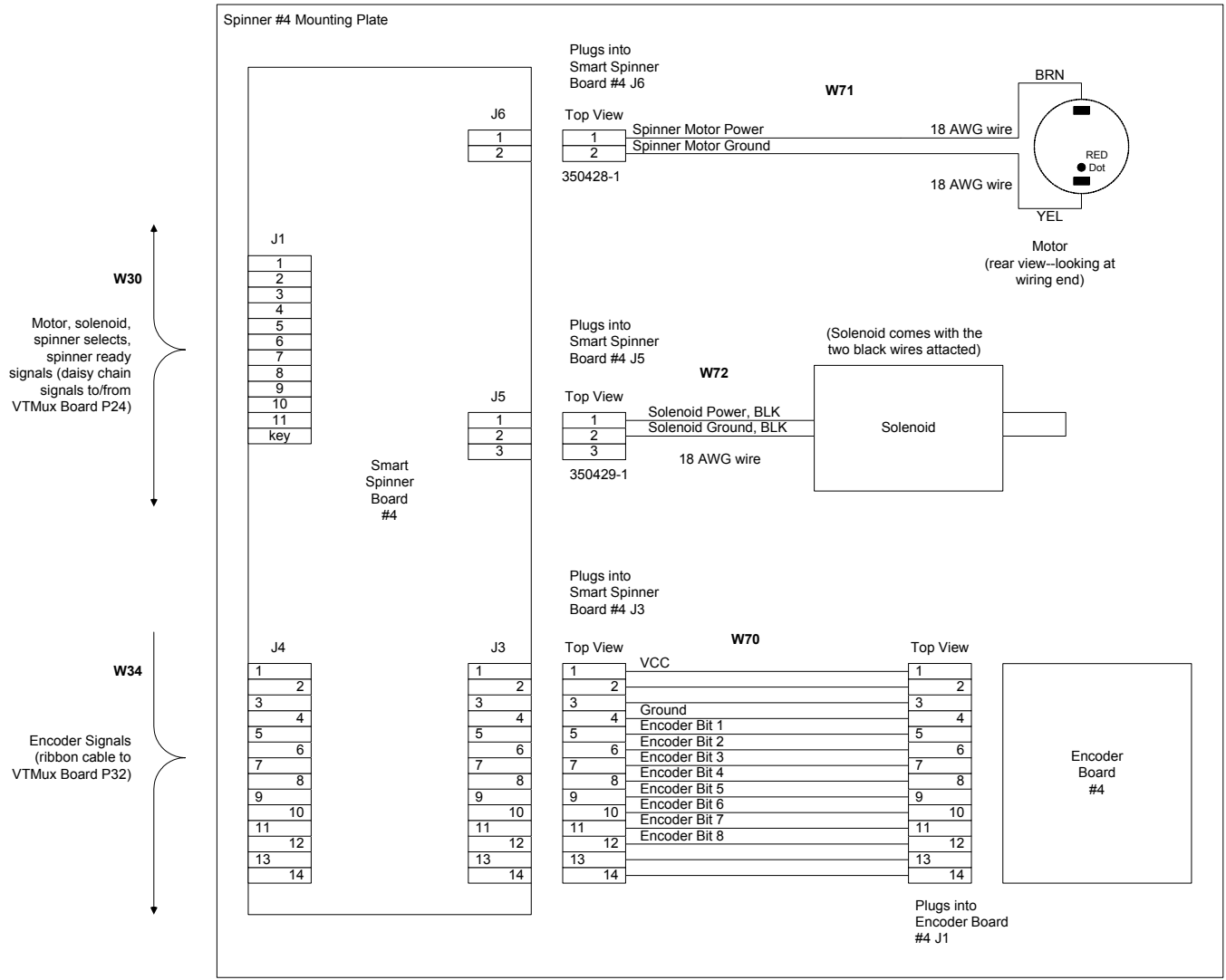

FIGURE 11 SPINNER #4 SUBASSEMBLY
W40 SPINNER BOARD #4 J3 TO ENCODER BOARD #4 J1
W41 SPINNER BOARD #4 J6 TO SPINNER MOTOR
W42 SPINNER BOARD #4 J5 TO SPINNER SOLENOID

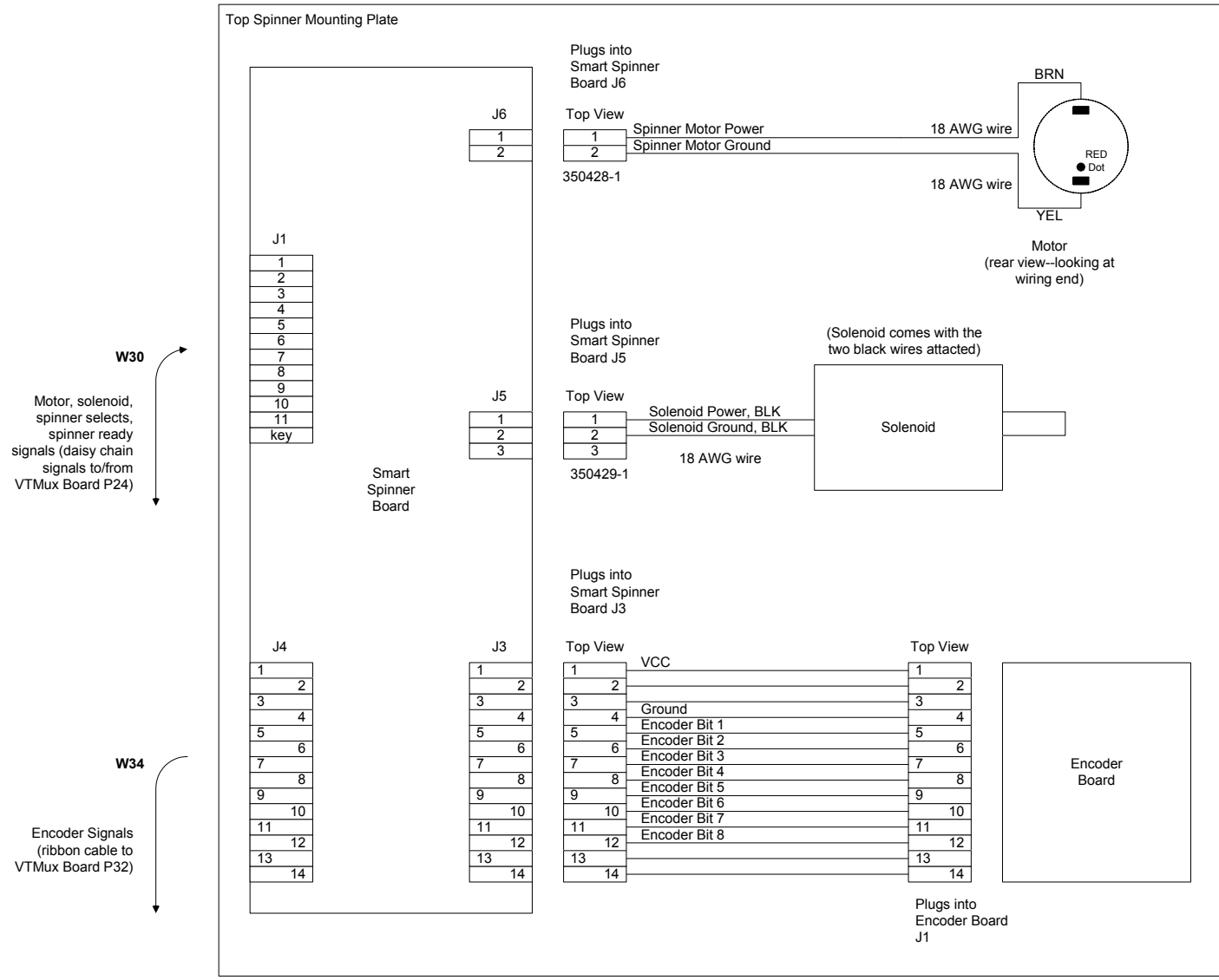

FIGURE 12 SPINNER #5 SUBASSEMBLY
W40 SPINNER BOARD #5 J3 TO ENCODER BOARD #4 J1
W41 SPINNER BOARD #5 J6 TO SPINNER MOTOR
W42 Spinner Board #5 J5 to Spinner Solenoid

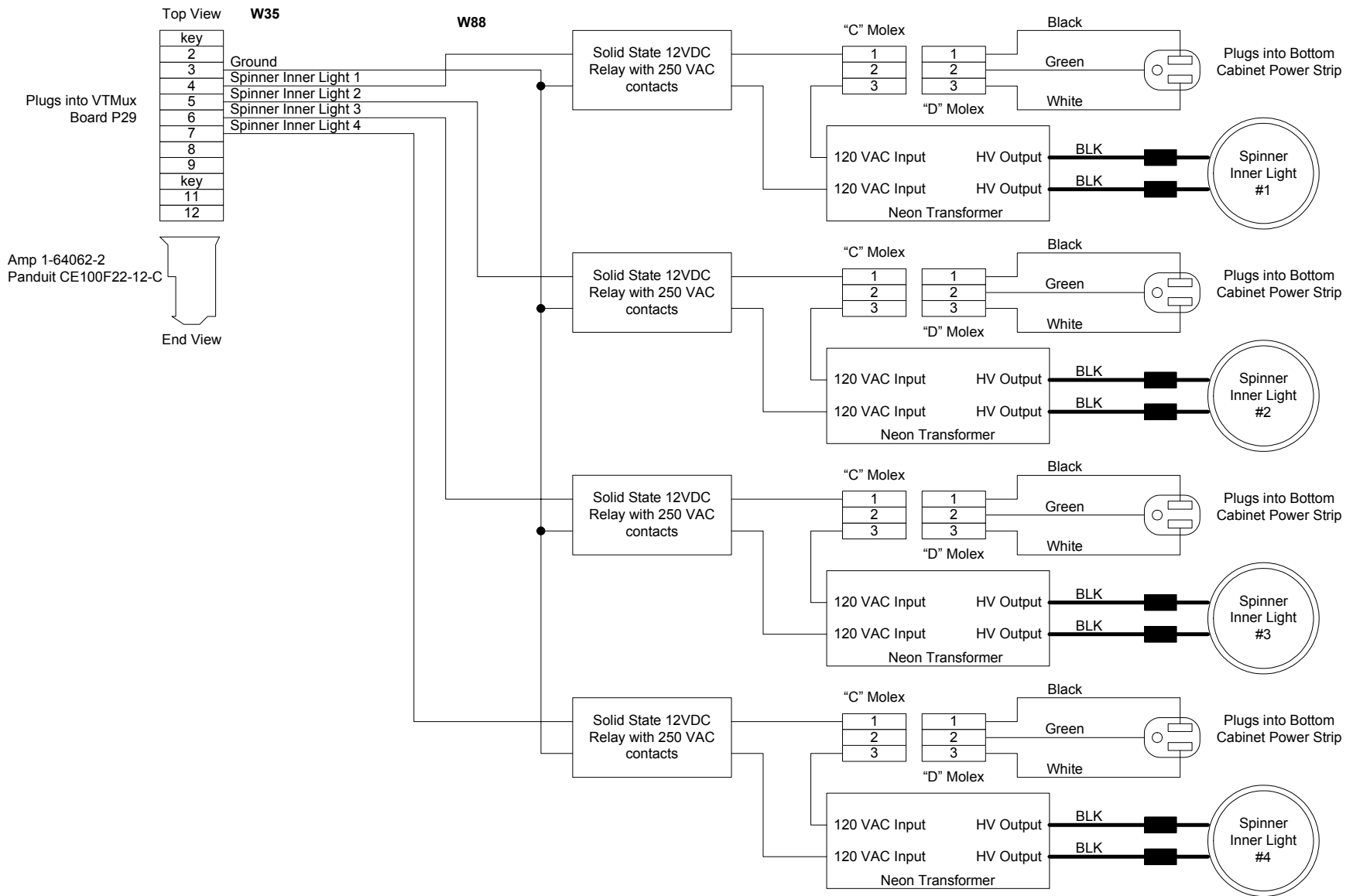

FIGURE 13 SPINNER'S 1 – 4 NEON RINGS WIRING
W35 VTMUX BOARD P29 TO SPINNER #1-5 NEON TRANSFORMERS AND LIGHTS

Wiring Diagrams

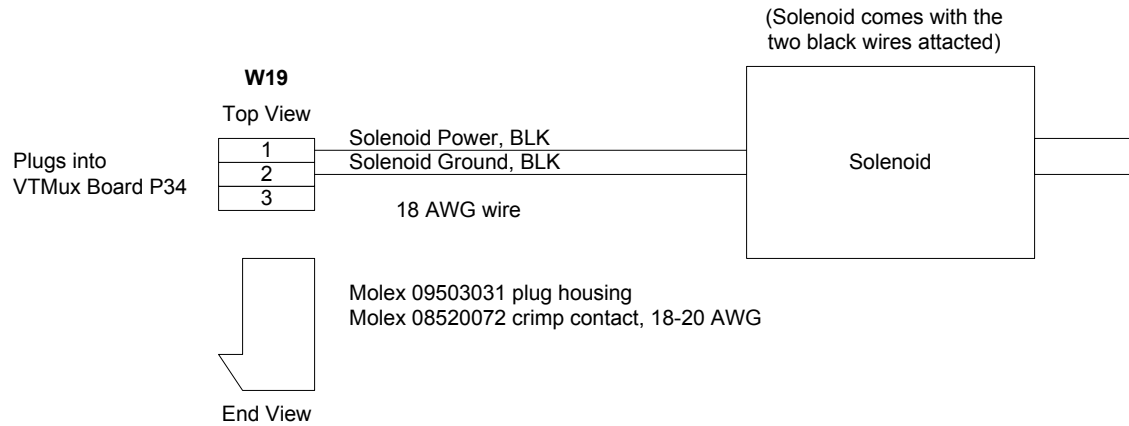

FIGURE 14 VTMUX BOARD P34 TO BRAKE SOLENOID

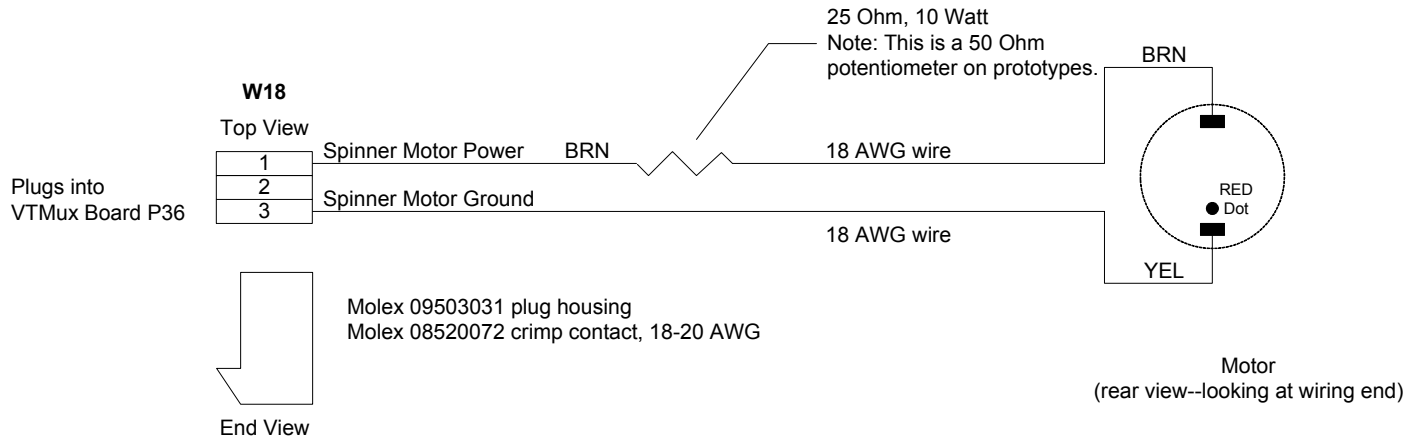

FIGURE 15 VTMUX BOARD P34 TO SPINNER MOTOR

Wiring Diagrams

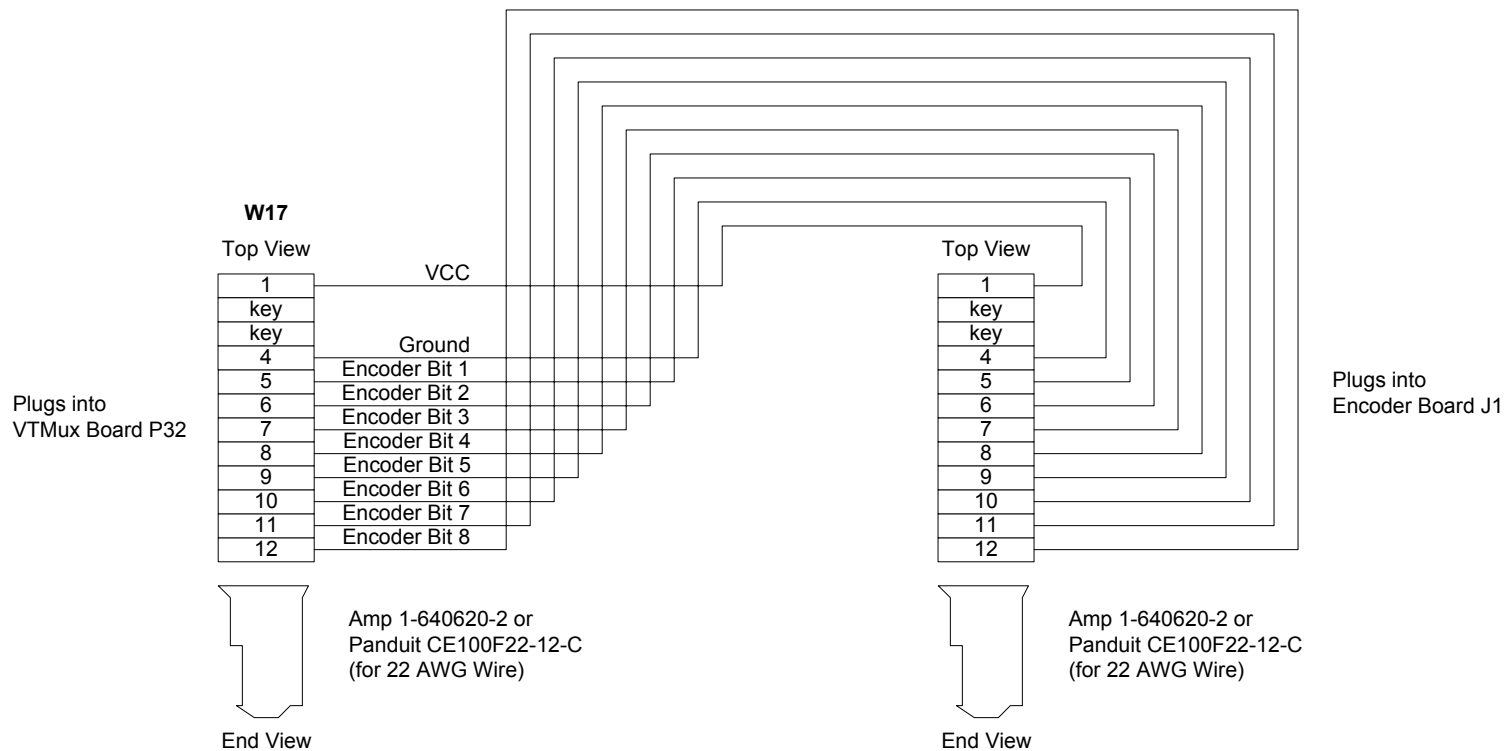

FIGURE 16 VTMUX BOARD P32 TO SPINNER SHAFT ENCODER

Wiring Diagrams

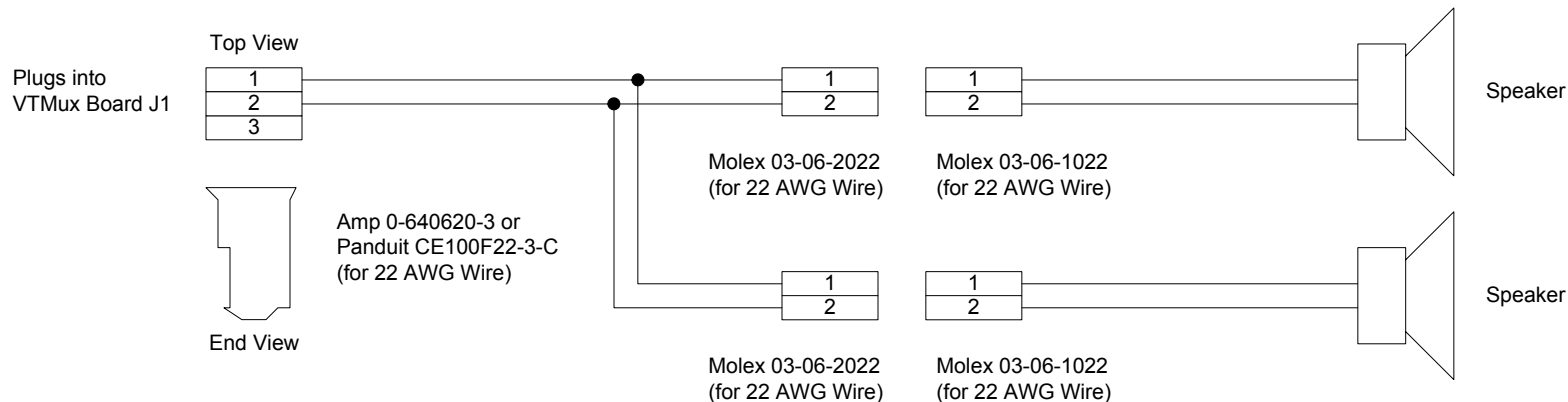

FIGURE 17 VTMUX BOARD J1 TO LOUDSPEAKER

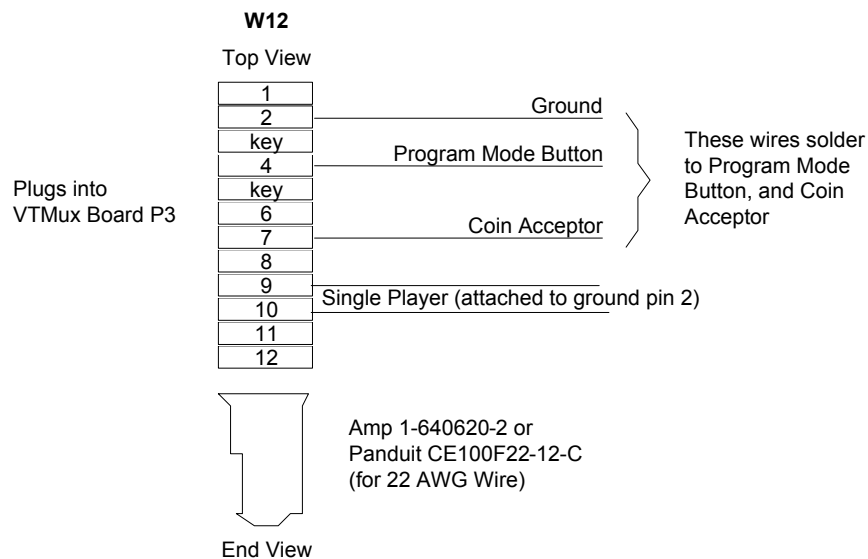

FIGURE 18 VTMUX BOARD P3 TO PROGRAM MODE BUTTON, SINGLE PLAYER, FOUR SPINNERS PRESENT, AND COIN ACCEPTOR

Wiring Diagrams

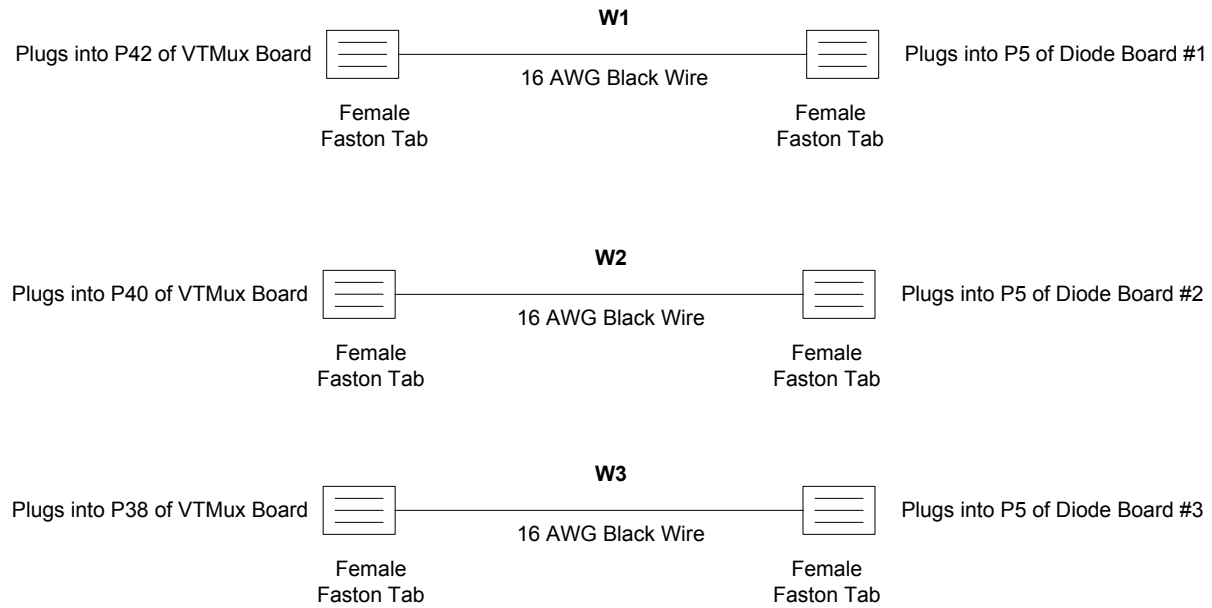

FIGURE 19 VTMUX BOARD P42, P40, AND P38 TO DIODE BOARDS P5S

Wiring Diagrams

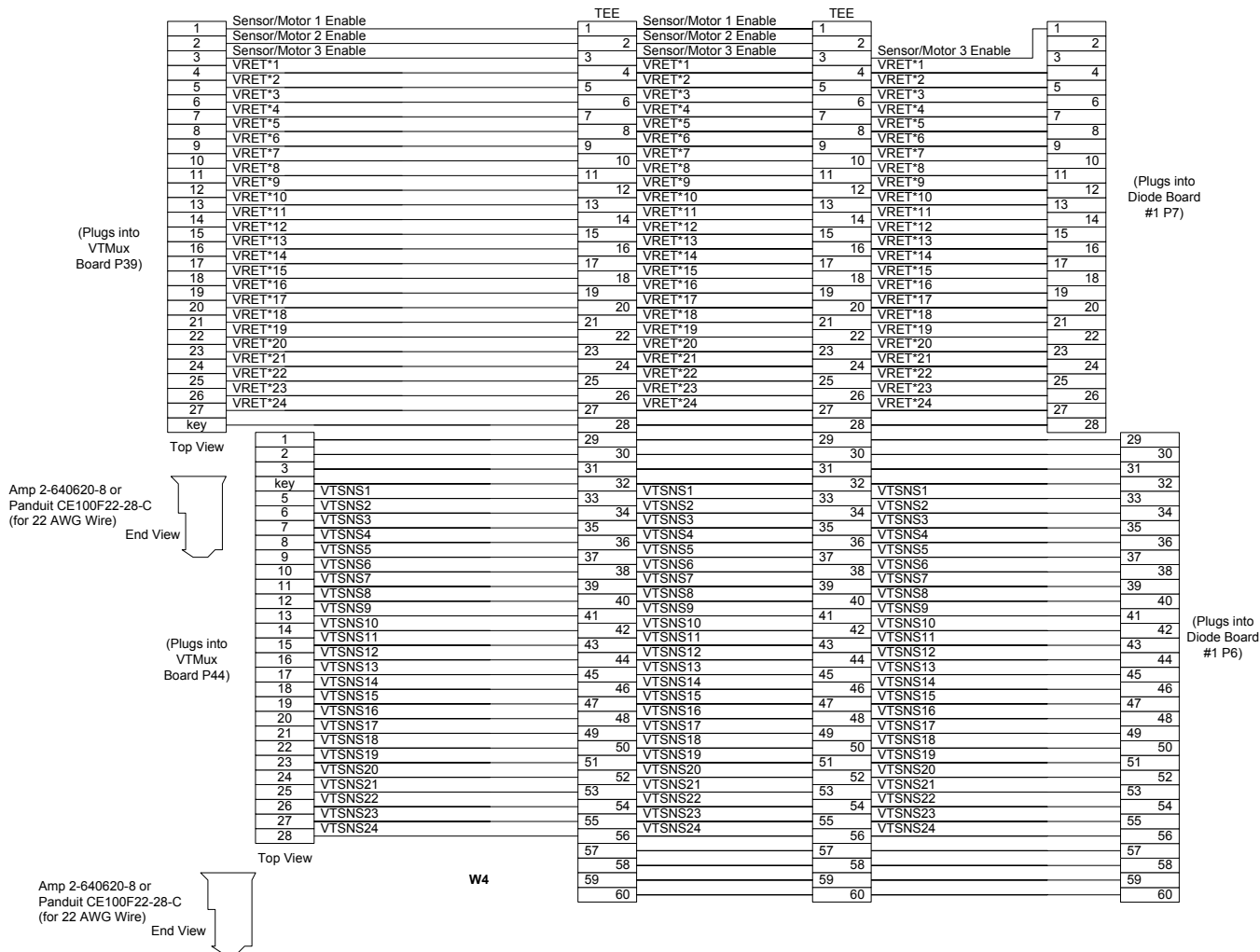

FIGURE 20 VTMUX BOARD P39 TO DIODE BOARD P7S

Wiring Diagrams

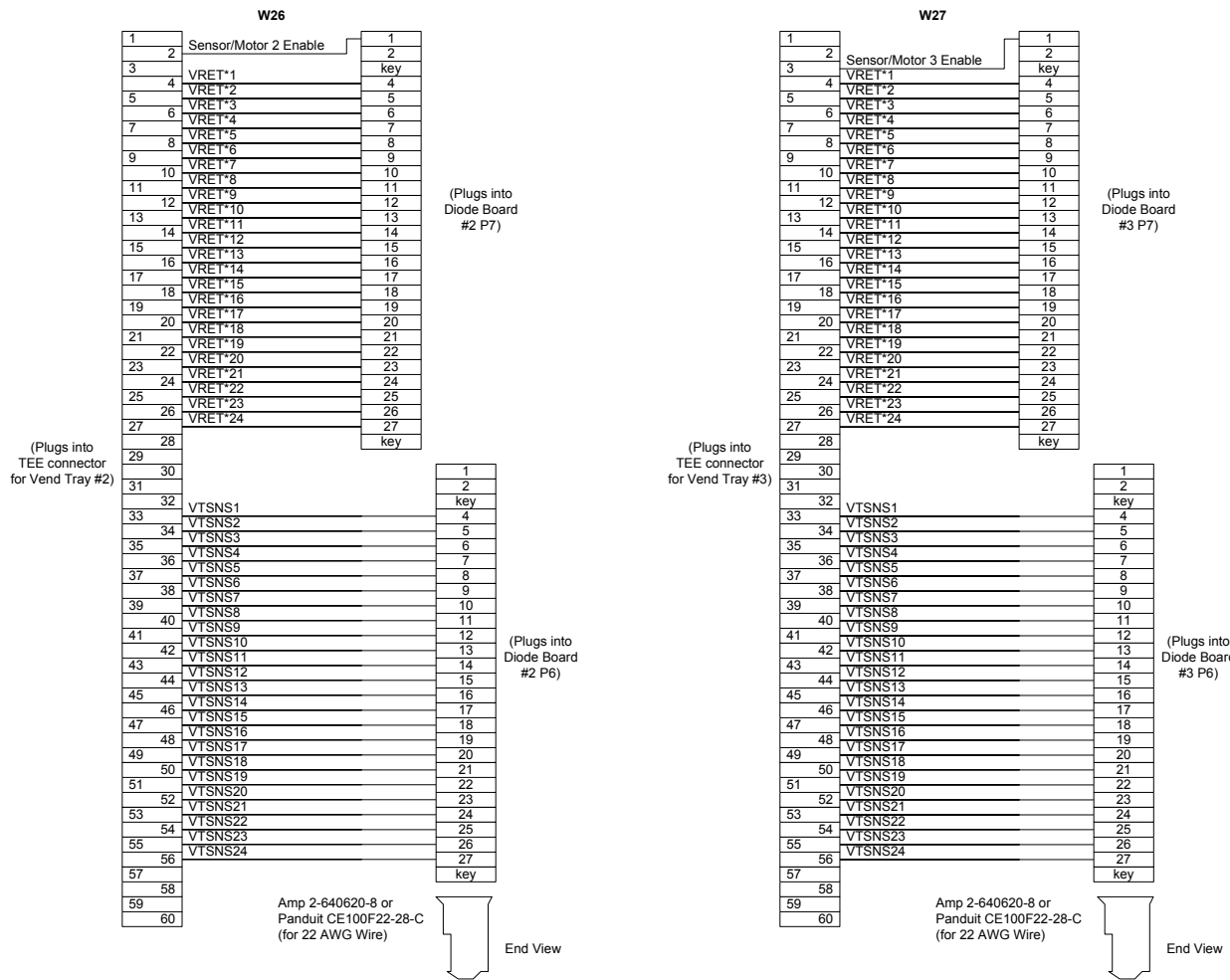

FIGURE 21A 60-PIN RIBBON CABLE TEE TO DIODE BOARD #2 P7
FIGURE 21B 60-PIN RIBBON CABLE TEE TO DIODE BOARD #3 P7

Wiring Diagrams

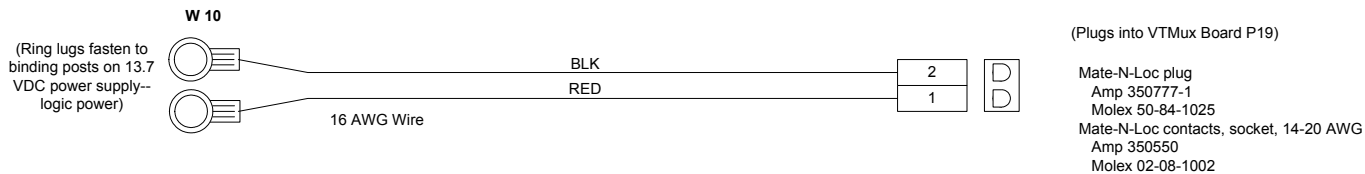

FIGURE 22 13.7 VDC POWER SUPPLY TO 8051 VTMUX BOARD P19

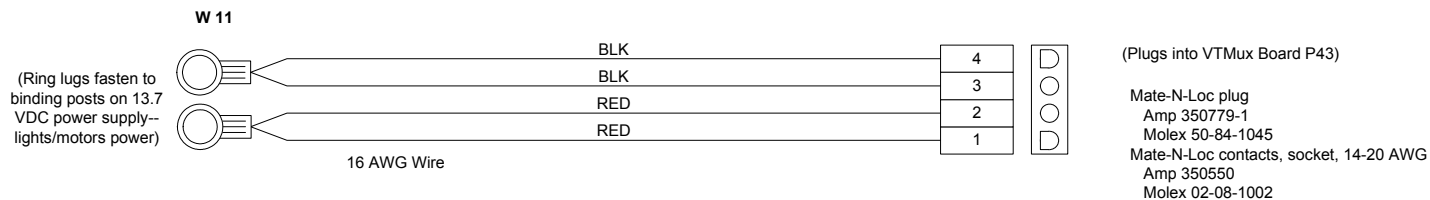

FIGURE 23 -13.7 VDC POWER SUPPLY TO 8051 VTMUX BOARD P43

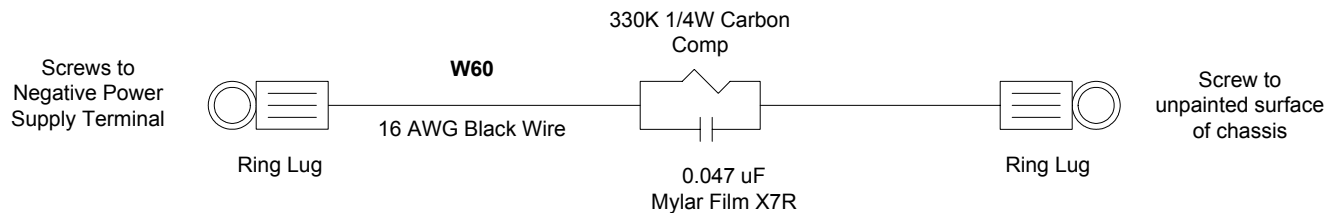

FIGURE 20 CHASSIS GROUND

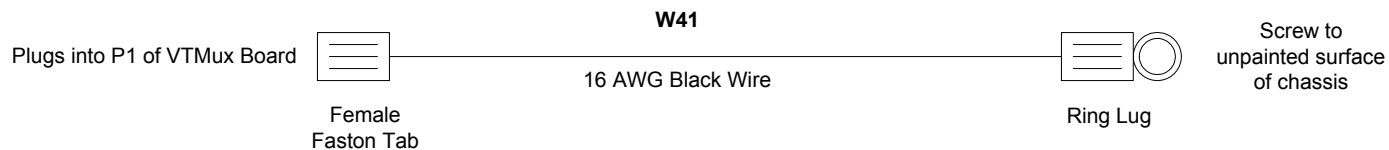

FIGURE 21 - AUDIO GROUND

Wiring Diagrams

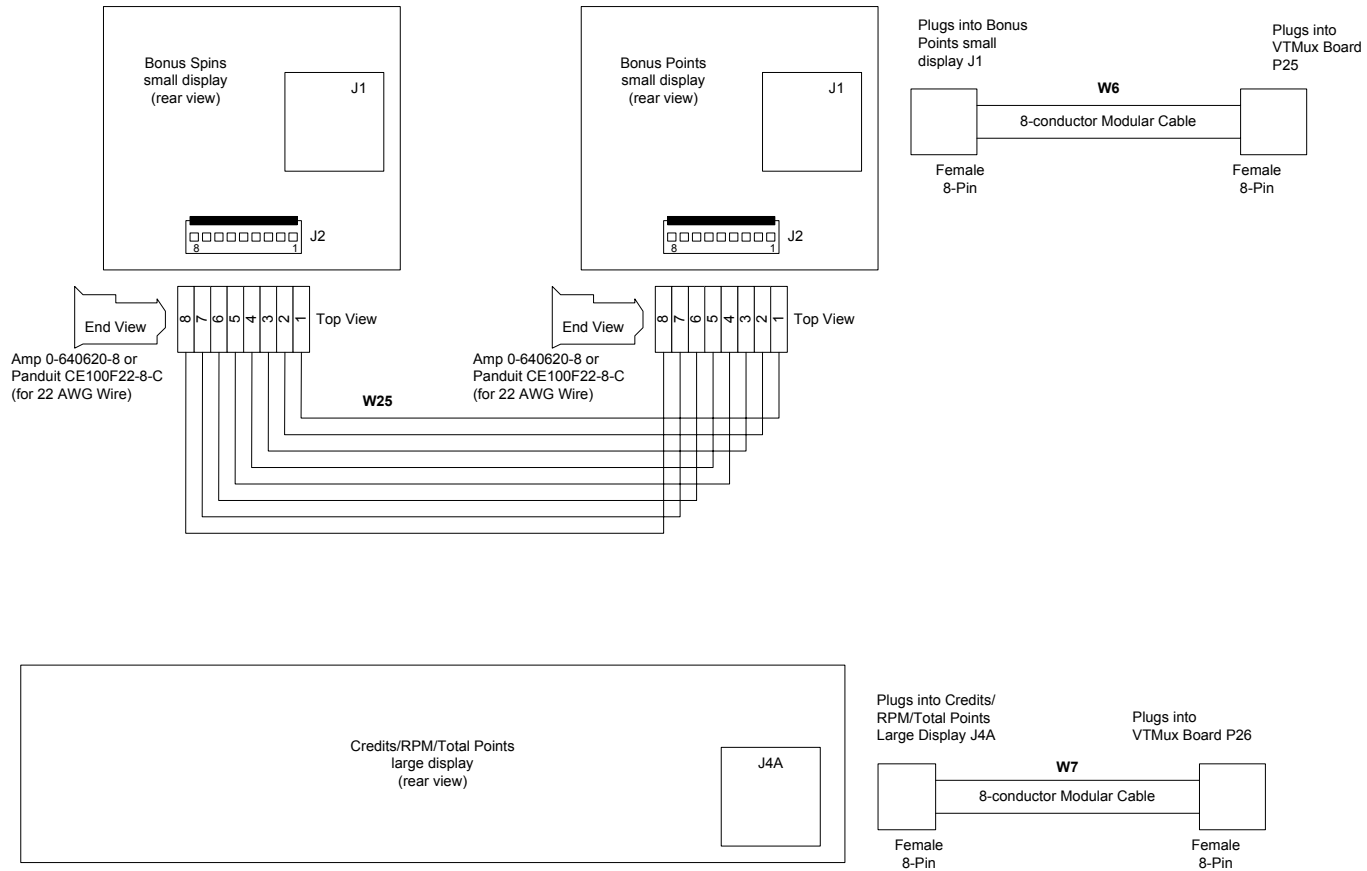

FIGURE 24A VTMUX BOARD P25 TO BONUS POINTS SMALL DISPLAY J1
FIGURE 24B BONUS POINTS SMALL DISPLAY J2 TO BONUS SPINS SMALL DISPLAY J2
FIGURE 24C VTMUX BOARD P26 TO CREDITS/RPM/TOTAL POINTS LARGE DISPLAY J4A

Wiring Diagrams

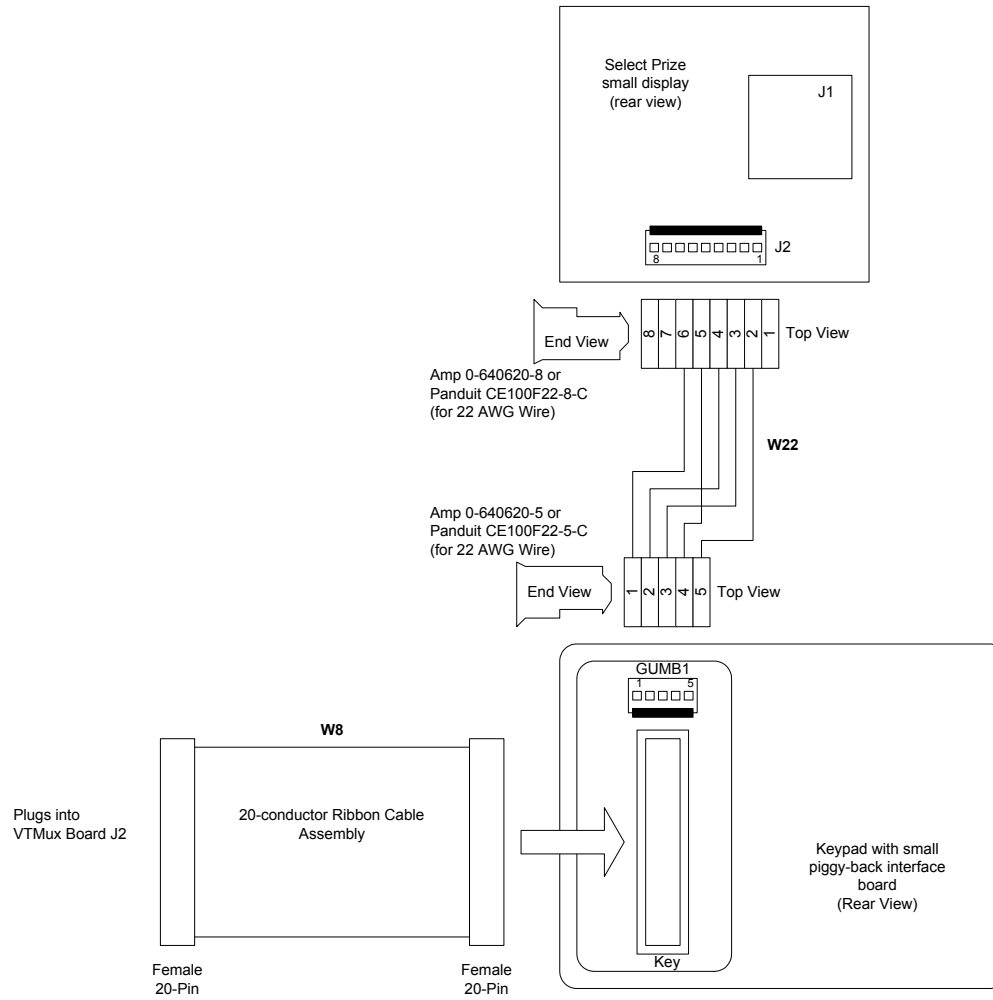

FIGURE 25A – VTMUX BOARD J2 TO KEYPAD KEY

FIGURE 25B - KEYPAD GUMB1 TO SELECT PRIZE SMALL DISPLAY J2

Wiring Diagrams

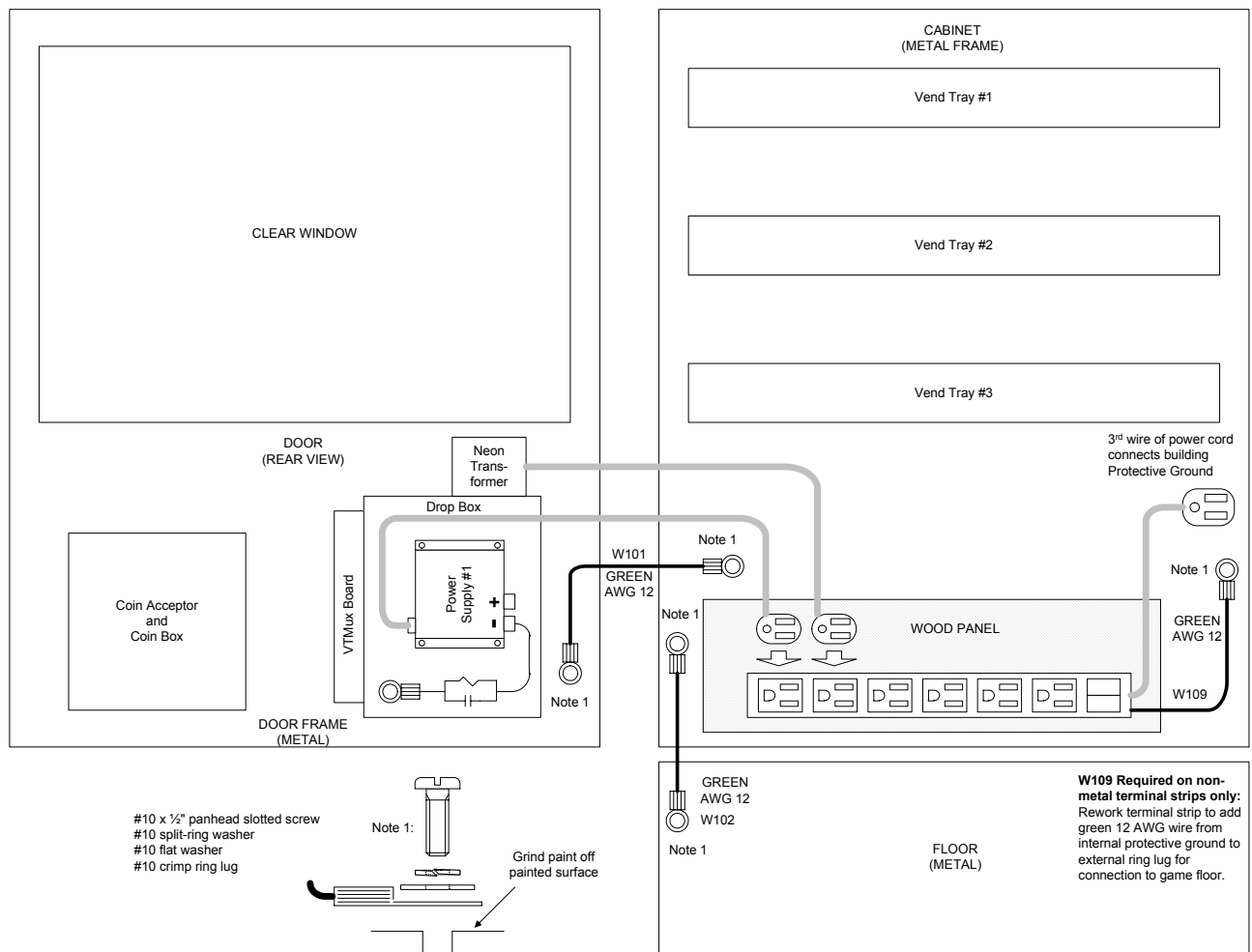
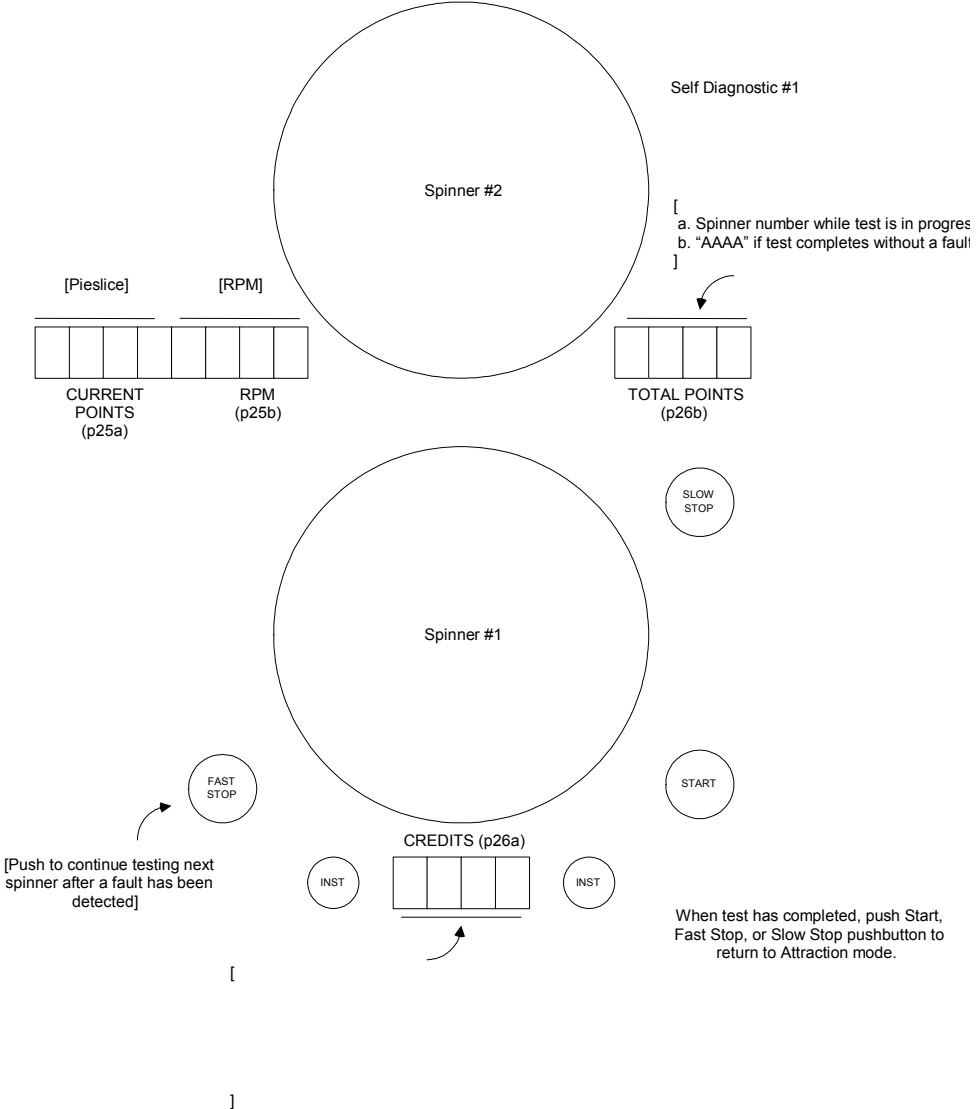

FIGURE 26 - PROTECTIVE GROUND WIRING

GAME SELF DIAGNOSTICS

Appendix A

When in Attraction mode push Call Attendant and Fast Stop pushbuttons for 10 seconds to perform Self Diagnostic #1



SELF DIAGNOSTIC #1 TEST LAYOUT

GAME SELF DIAGNOSTICS

SELF DIAGNOSTIC #1

To enter game diagnostics HOLD IN the *CALL ATTENDANT* & *FAST STOP BUTTON*'s simultaneously for approximately ten seconds. Upon a successful completion of the diagnostics the total points display should show **AAAA**.

Self Diagnostic #1 ERROR CODE CHART

Phase	Situation	Error Codes	Solution
1	Brake Assembly Test	001	Brake # 1 Needs Repair
		002	Brake # 2 Needs Repair.
		003	Brake # 3 Needs Repair
		004	Brake # 4 Needs Repair
		005	Brake # 5 Needs Repair
2	Smart Spinner Encoder Reader Board Test	011	First Replace Encoder Reader #1, Next Smart Spinner # 1
		012	First Replace Encoder Reader #2, 2 nd Smart Spinner #2
		013	First Replace Encoder Reader #3, 2 nd Smart Spinner #3
		014	First Replace Encoder Reader #4, 2 nd Smart Spinner #4
		015	First Replace Encoder Reader #5, 2 nd Smart Spinner #5
3	Smart Spinner Dip Switch Conflict or Cabling Test	103	Dip switch Conflict with Smart Spinner Boards # 1,2
		105	Dip switch Conflict with Smart Spinner Boards # 1,3
		106	Dip switch Conflict with Smart Spinner Boards # 2,3
		107	Dip switch Conflict with Smart Spinner Boards # 1,2,3
		109	Dip switch Conflict with Smart Spinner Boards # 1,4
		110	Dip switch Conflict with Smart Spinner Boards # 2,4
		111	Dip switch Conflict with Smart Spinner Boards # 1,2,4
		112	Dip switch Conflict with Smart Spinner Boards # 3,4
		113	Dip switch Conflict with Smart Spinner Boards # 1,3,4
		114	Dip switch Conflict with Smart Spinner Boards # 2,3,4
		115	Dip switch Conflict with Smart Spinner Boards # 1,2,3,4
		117	Dip switch Conflict with Smart Spinner Boards # 1,5
		118	Dip switch Conflict with Smart Spinner Boards # 2,5
		119	Dip switch Conflict with Smart Spinner Boards # 1,2,5
		120	Dip switch Conflict with Smart Spinner Boards # 3,5
		121	Dip switch Conflict with Smart Spinner Boards # 1,3,5
		122	Dip switch Conflict with Smart Spinner Boards # 2,3,5
		123	Dip switch Conflict with Smart Spinner Boards # 1,2,3,5
		124	Dip switch Conflict with Smart Spinner Boards # 4,5
		125	Dip switch Conflict with Smart Spinner Boards # 1,4,5
126	Dip switch Conflict with Smart Spinner Boards # 2,4,5		
127	Dip switch Conflict with Smart Spinner Boards # 1,2,4,5		
128	Dip switch Conflict with Smart Spinner Boards # 3,4,5		
129	Dip switch Conflict with Smart Spinner Boards # 1,3,4,5		
130	Dip switch Conflict with Smart Spinner Boards # 2,3,4,5		
4	Smart Spinner Board or Incorrect DIP Switch Setting	011	If DIP switch Correct, replace Smart Spinner Board #1
		012	If DIP switch Correct, replace Smart Spinner Board #2
		013	If DIP switch Correct, replace Smart Spinner Board #3
		014	If DIP switch Correct, replace Smart Spinner Board #4
		015	If DIP switch Correct, replace Smart Spinner Board #5
5	Encoder Board Test	021	Replace Encoder Board #1

GAME SELF DIAGNOSTICS

Phase	Situation	Error Codes	Solution
		022	Replace Encoder Board #2
		023	Replace Encoder Board #3
		024	Replace Encoder Board #4
		025	Replace Encoder Board #5
6	Encoder Disk Test	041	Replace Encoder Disk #1
		042	Replace Encoder Disk #2
		043	Replace Encoder Disk #3
		044	Replace Encoder Disk #4
		045	Replace Encoder Disk #5

TROUBLESHOOTING ASSISTANCE

Appendix B

Troubleshooting Guide

Problem	Solution	Associated Program Step # (if applicable)
Game will not power up	<ul style="list-style-type: none"> • Verify 120 VAC power is present on cabinet power strips • Replace 13.7 VDC power supply 	<p style="text-align: center;">na</p> <p style="text-align: center;">na</p>
Pushbutton light does not illuminate	<ul style="list-style-type: none"> • Examine and replace any burned-out lamp • Measure low-voltage across terminals of lamp socket and if voltage not present when light should be on, check wiring harness • Measure low-voltage at output from VTMux board and if voltage not present when light should be on, replace VTMux board and retest 	<p style="text-align: center;">na</p> <p style="text-align: center;">na</p> <p style="text-align: center;">na</p>
Game does not respond to pushing a flashing pushbutton	<ul style="list-style-type: none"> • Check number of coins required to play setting • Examine and replace any defective pushbutton • Look for low-voltage changes at VTMux board input when pushbutton pushed and if voltage does not change, check wiring harness • Replace VTMux board and retest 	<p style="text-align: center;">Step 30</p> <p style="text-align: center;">na</p> <p style="text-align: center;">na</p> <p style="text-align: center;">na</p>
Does not respond when coin/token inserted	<ul style="list-style-type: none"> • Examine and replace any defective coin acceptor mechanism • Look for low-voltage changes at VTMux board input when coin/token inserted and if voltage does not change, check wiring harness • Replace VTMux board and retest 	<p style="text-align: center;">na</p> <p style="text-align: center;">na</p> <p style="text-align: center;">na</p>
No sound	<ul style="list-style-type: none"> • Check VOLUME potentiometer on VTMux board and turn clockwise to increase volume • Examine and replace any defective speaker • Check wiring harness • Replace VTMux board and retest 	<p style="text-align: center;">na</p> <p style="text-align: center;">na</p> <p style="text-align: center;">na</p> <p style="text-align: center;">na</p>
Does not dispense tickets	<ul style="list-style-type: none"> • Clear ticket dispenser of any jammed tickets • Load tickets if empty • Try dispensing a ticket using diagnostic mode, if ticket does not dispense: <ul style="list-style-type: none"> ○ Check wiring harness ○ Replace ticket dispenser and retest ○ Replace VTMux board and retest 	<p style="text-align: center;">na</p> <p style="text-align: center;">na</p> <p style="text-align: center;">Step 78</p> <p style="text-align: center;">na</p> <p style="text-align: center;">na</p>

TROUBLESHOOTING ASSISTANCE

Problem	Solution	Associated Program Step # (if applicable)
4-digit display always blank or shows gibberish	<ul style="list-style-type: none"> • Replace 4-digit display and retest • Replace VTMux board and retest • Check wiring harness 	<p style="text-align: center;">na</p> <p style="text-align: center;">na</p> <p style="text-align: center;">na</p>
Spinner light-ring does not illuminate	<ul style="list-style-type: none"> • Look for low-voltage changes at VTMux board output when light-ring should be illuminated and if voltage does not change, replace VTMux board and retest • Look for low-voltage changes at input to solid state relay when light-ring should be illuminated and if voltage does not change, check wiring harness • Look for 120 VAC voltage changes at output from solid state relay when light-ring should be illuminated: <ul style="list-style-type: none"> ○ If voltage does not change, replace solid state relay and retest ○ If voltage does change, replace light-ring and/or neon high-voltage transformer and retest (CAUTION— EXTREMELY DANGEROUS HIGH VOLTAGE) 	<p style="text-align: center;">na</p> <p style="text-align: center;">na</p> <p style="text-align: center;">na</p> <p style="text-align: center;">na</p> <p style="text-align: center;">na</p>
Spinner does not spin	<ul style="list-style-type: none"> • Troubleshoot spinner motors 	<p style="text-align: center;">Step 76</p>
Spinner brake does not operate	<ul style="list-style-type: none"> • Troubleshoot spinner brakes 	<p style="text-align: center;">Step 76</p>
SOME spinners CONSISTENTLY give wrong POINTS	<ul style="list-style-type: none"> • Verify correct POINT programming: <ul style="list-style-type: none"> ○ Spinner #1 ○ Spinner #2 ○ Spinner #3 ○ Spinner #4 ○ Spinner #5 • Troubleshoot spinner boards and calibrate spinner(s) (requires access to spinner mechanism) • Troubleshoot spinner boards and spinner mechanism (does not require access to spinner mechanism, but does not allow calibration of spinner to TDC) 	<p style="text-align: center;">Steps 100-115</p> <p style="text-align: center;">Steps 200-215</p> <p style="text-align: center;">Steps 300-315</p> <p style="text-align: center;">Steps 400-415</p> <p style="text-align: center;">Steps 500-515</p> <p style="text-align: center;">Step 71-75</p> <p style="text-align: center;">Steps 76</p>
SOME spinners INTERMITTENTLY give wrong POINTS	<ul style="list-style-type: none"> • Troubleshoot spinners and spinner boards for intermittent problems 	<p style="text-align: center;">Step 79</p>
ALL spinners CONSISTENTLY give wrong POINTS	<ul style="list-style-type: none"> • Verify correct POINT programming: <ul style="list-style-type: none"> ○ Spinner #1 ○ Spinner #2 ○ Spinner #3 	<p style="text-align: center;">Steps 100-115</p> <p style="text-align: center;">Steps 200-215</p> <p style="text-align: center;">Steps 300-315</p>

TROUBLESHOOTING ASSISTANCE

	<ul style="list-style-type: none"> ○ Spinner #4 ○ Spinner #5 • Troubleshoot spinner boards and wiring harness for data bus jamming 	<p style="text-align: center;">Steps 400-415</p> <p style="text-align: center;">Steps 500-515</p> <p style="text-align: center;">Step 79</p>
<p style="text-align: center;">SOME spinners CONSISTENTLY cause a JUMP to wrong spinner</p>	<ul style="list-style-type: none"> • Verify correct POSITION TYPE programming: <ul style="list-style-type: none"> ○ Spinner #1 ○ Spinner #2 ○ Spinner #3 ○ Spinner #4 ○ Spinner #5 • Troubleshoot spinner boards and calibrate spinner(s) if required (requires access to spinner mechanism) • Troubleshoot spinner boards and spinner mechanism (does not require access to spinner mechanism, but does not allow calibration of spinner to TDC) 	<p style="text-align: center;">Steps 150-173</p> <p style="text-align: center;">Steps 250-273</p> <p style="text-align: center;">Steps 350-373</p> <p style="text-align: center;">Steps 450-473</p> <p style="text-align: center;">Steps 550-573</p> <p style="text-align: center;">Step 71-75</p> <p style="text-align: center;">Steps 79</p>

Appendix C

TECHNICAL ASSISTANCE

Most distributors provide technical assistance for the products they sell. If your distributor cannot solve your problem, assistance can be obtained through Five Star Redemption. Call (818) 773-6057 extension 232 between the hours of 8:00 AM and 4:00 PM Pacific time, Monday through Friday, and ask for the service department.

Please have the following information available:

1. Type of Game
2. Serial Number
3. Distributor's Name
4. Description of Problem

The service technician may ask you to perform some tests on your machine, so it is preferable to call from the game's location if possible.

Five Star Redemption
ADDRESS AND TELEPHONE NUMBERS

8835 SHIRLEY AVENUE
NORTHRIDGE, CA 91324
(818) 773-6057 FAX (818) 773-6064
SALES EXTENSION 232
TECHNICAL SUPPORT EXTENSION 235